

## Instruction Manual Body Composition Analyzer DC-240

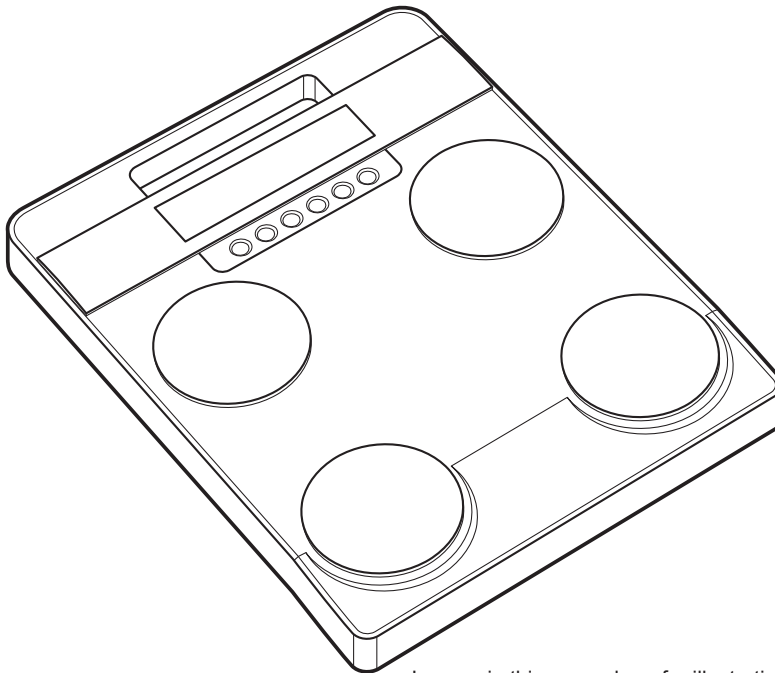

Images in this manual are for illustrative purposes only.

### <Usage Conditions>

Temperature Range	: 41 to 95°F/5 to 35°C
Relative Humidity Range	: 30 to 80% (without condensation)
Maximum Altitude	: 6,500ft ASL/2,000m ASL
Atmospheric Pressure Range	: 86 to 106kPa

### <Storage/Transport Conditions>

Temperature Range	: 14 to 140°F/-10 to 60°C
Relative Humidity Range	: 10 to 90% (without condensation)
Atmospheric Pressure Range	: 70 to 106kPa

To avoid malfunctions, avoid storing the equipment in a location that is subject to direct sunlight, significant temperature changes, dampness, large amounts of dust, the risk of vibration or impact, or near naked flames.



Please read this Instruction Manual carefully and keep it handy for future reference.

# Contents

---

<b>For Your Safety</b> .....	<b>3</b>
<b>Part Names &amp; Accessories</b> .....	<b>7</b>
<b>Names and Functions of Display Panel &amp; Operation Keys</b> .....	<b>8</b>
<b>Preparation</b> .....	<b>9</b>
<b>Power Supply</b> .....	<b>10</b>
<b>Various Settings</b> .....	<b>11</b>
<b>How to Use (Mode Selection)</b> .....	<b>12</b>
<b>How to Use (Body Composition Mode)</b> .....	<b>13</b>
<b>How to Use (Scale Mode)</b> .....	<b>16</b>
<b>How to Use (Scale: Weight Lock Mode)</b> .....	<b>17</b>
<b>How to Use (Scale: BMI Mode)</b> .....	<b>18</b>
<b>Troubleshooting</b> .....	<b>19</b>
<b>Technical Notes</b> .....	<b>20</b>
<b>Specifications</b> .....	<b>26</b>

## Disposal

---



This equipment is electronic device. Please dispose of this equipment appropriately as not general household waste but electronic equipment. Please follow a regional regulation when you dispose of this.

## Intended Use

---

The TANITA body composition analyzer is a medical device intended to measure weight and impedance, and to estimate body composition, such as the body fat percentage, total body water percentage, muscle mass, bone mass, visceral fat rating, basal metabolic rate (BMR), fat mass, body mass index(BMI), and metabolic age using a noninvasive method on Bioelectrical Impedance Analysis (BIA). DC-240 is indicated for use for healthy children 5–17 years old and healthy adults with active, moderately active, to inactive lifestyles.

## Efficacy

---

1. This product is simple to use, and requires no specialized facilities or expertise to take measurements.
2. Measurements can be taken quickly and easily, causing minimal inconvenience to the patient during measurements.





This section explains precautionary measures to be taken to avoid injury to the patients and operators of this product, and to prevent damage to property. Please familiarize yourself with this information to ensure safe operation of this product.

## Contraindication







**This product must not be used on subjects with pacemakers or other mechanical implants.**

This product passes a weak electrical current through the body which could interfere with and cause the malfunction of electrical medical implants, resulting in serious repercussions.

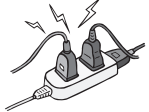

	<b>Warning</b>	Failure to follow instructions highlighted with this mark could result in death or severe injury.
	<b>Caution</b>	Failure to follow instructions highlighted with this mark could result in injury or damage to property.
	Prohibited	This mark indicates actions that are prohibited.
	Required	This mark indicates instructions that must always be followed.

## Warning

	<b>Do not handle the plug with a wet hand.</b> Such action may result in electric shock, fire, or leakage.	
	<b>Keep this product away from flammable gas and oxygen rich environment.</b>	
	<b>No modification of this product is allowed.</b> There is a risk of electrocution or injury. Nor can precise analysis be guaranteed.	
	<b>Do not use double adapters.</b> May result in fire.	
	<b>Do not use the product if you have any kind of wound or inflammation on any part of your body that comes into direct contact with the product.</b>	
	<b>Do not judge the evaluation of measurement results.</b> Consult your doctor before you start a body weight management program.	
	<b>Use only a correctly wired outlet.</b> Only genuine cables and equipment are allowed.	

# For Your Safety (Continue)

## Caution



Prohibited

**Keep off wet circumstance.**

**Avoid using on subjects with allergies to metals.**

Allergic reactions may be caused by the stainless steel used in the electrodes of this product.

**Do not jump on the product.**

**Do not use this product near other products that emit electromagnetic waves.**

**Do not insert fingers into gaps and holes.**

**Do not apply force to the display.**

The screen panel may break and cause injury.

**Do not place items sensitive to magnetic forces near the product.**

The magnet of the impedance meter may cause corruption of data on devices such as USB memory sticks if these are placed near the product.

**Assist persons with disabilities.**

Another person should assist persons with disabilities who may not be able to take a measurement alone.



Required

**Be sure to clean the scale platform with appropriate disinfectant after each use.**

**For your safety to avoid the risk of electric shock and to secure the accuracy, keep a clearance with patients during measuring.**

**Continually monitor both the subject and the product for anomalies.**

Should an anomaly with the subject or the product be discovered, take appropriate action, such as stopping the product, while ensuring the safety of the subject.

**Be sure to use the designated AC adapter.**

**Unplug the AC cable from the product when moving it.**

**Do not interpret analysis results yourself (including evaluating measurements and formulating exercise programs based on results, etc.).**

Weight loss and exercise based on self-analysis could be detrimental to your health. Always follow the advice of a qualified professional.

**This product may only be operated by healthcare professionals.**

## For Accurate Measurements

### **Avoid measuring after hard exercise.**

May result in measurement errors. Please take measurements after sufficient rest.



Prohibited

### **Avoid measuring after over-eating or over-drinking, and when severely dehydrated.**

May result in measurement errors. For greater accuracy, avoid using directly after waking up. Use at the same time on each occasion, at least three hours after eating.



### **Do not take measurements while using transmitters, such as mobile phones, which may affect readings.**

### **Use the product under the same conditions and in the same position as much as possible to track changes.**

Readings are greatly affected by the level of hydration and position of the body. Please use at the same time each day, under the same conditions and in the same body position.



### **Avoid measuring in multiple locations with greatly differing temperatures.**

This may cause inaccurate measurements. Allow the product to stand for at least 2 hours before using if it is moved to a new location with a temperature difference of 36°F/20°C or more.



Required

### **Always hold both arms straight down when taking measurements to prevent measurement errors such as undermeasurement of body fat.**

**Bare feet should be placed correctly on the electrode platform.  
Place arms straight down during measurement.**

### **Use in a stable location.**

Errors in measurements may occur when the product is used in an unstable location.

# For Your Safety (Continue)

## Scheduled Maintenance



**Required**

**TANITA recommends that each facility conduct periodic checks of each unit.**

1. Check the following at least daily:
  - The unit is on a stable and level surface i.e. on a firm flooring, not on a thick carpet
2. Visually inspect the following at least weekly:
  - The display for any damage or contamination
  - All cables, cords, and connector ends for damage or contamination
  - All safety-related labeling for legibility
  - All accessories (sensors, electrodes, etc.) for wear or damage
3. Visually inspect the following at least monthly:

**Update settings, replace items, or call for service as necessary according to the results of the visual inspections. Do not use the unit if you see any signs of damage. Product that has been damaged must be checked for proper operation by qualified personnel before using again.**

# Part Names & Accessories

## Front

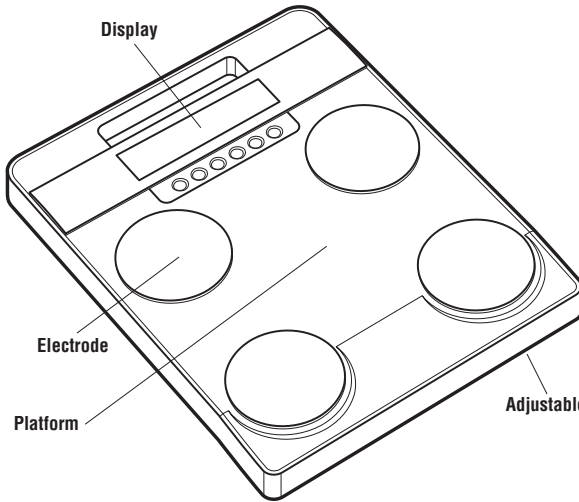

## Back

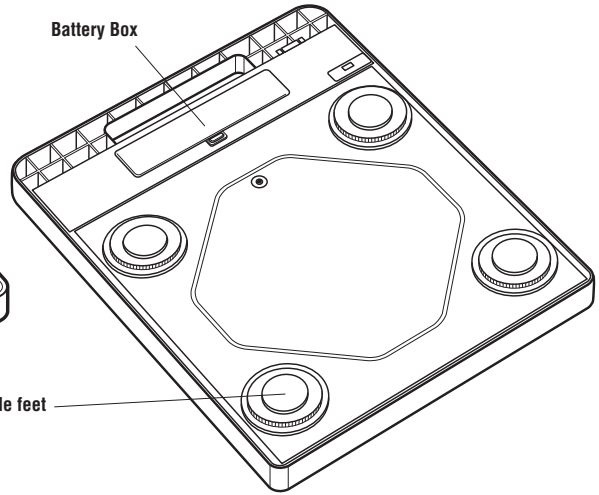

### The correct direction of the adjustable feet

If the adjustable feet came off, attach these in the direction of the following figure.  
The product will not work if attached incorrectly.

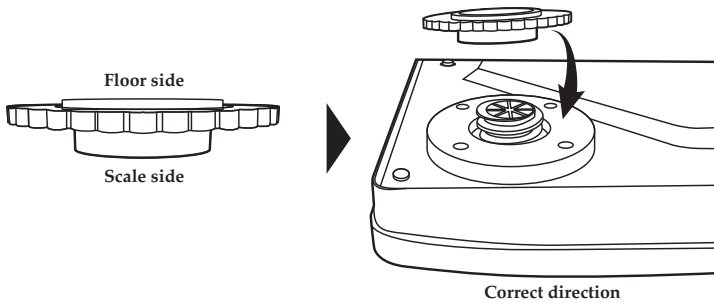

### Accessories

- Instruction manual (this book)
- AC adapter

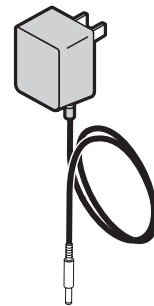

# Names and Functions of Display Panel & Operation Keys

## Meanings of the Display Panel & Operation Keys

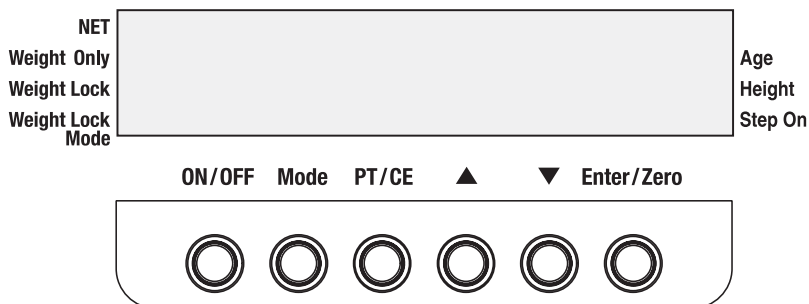

<b>NET</b>	Indicates that the clothes weight is input
<b>Weight Only</b>	Indicates that the Weight Only (Scale) Mode
<b>Weight Lock</b>	Indicates that the Weight is locking
<b>Weight Lock Mode</b>	Indicates that the Weight Lock function is activated
<b>Age</b>	Indicates that the age is input
<b>Height</b>	Indicates that the height is input
<b>Step On</b>	Indicates that the measuring start

<b>ON</b>	Power ON	<b>OFF</b>	Power OFF	<b>Mode</b>	Select measurement mode
<b>PT</b>	Set preset tare value (Clothes weight)	<b>CE</b>	Clear input value		Value up
	Value down	<b>Enter</b>	Confirm the entered value	<b>Zero</b>	Reset zero point
	Male		Female		Athletic mode

## Symbols and Their Meanings

	Direct current		Alternating current		See the instructions
	Polarity of DC power connector		Class II Equipment		Input, Output
	WEEE - Waste Electrical and Electronic Equipment Directives		Polarity of a battery		Serial number
	Caution. Refer to the attached information		Manufacturer (Data of manufacture)		For indoor use only
	Type BF applied part				



## Using batteries

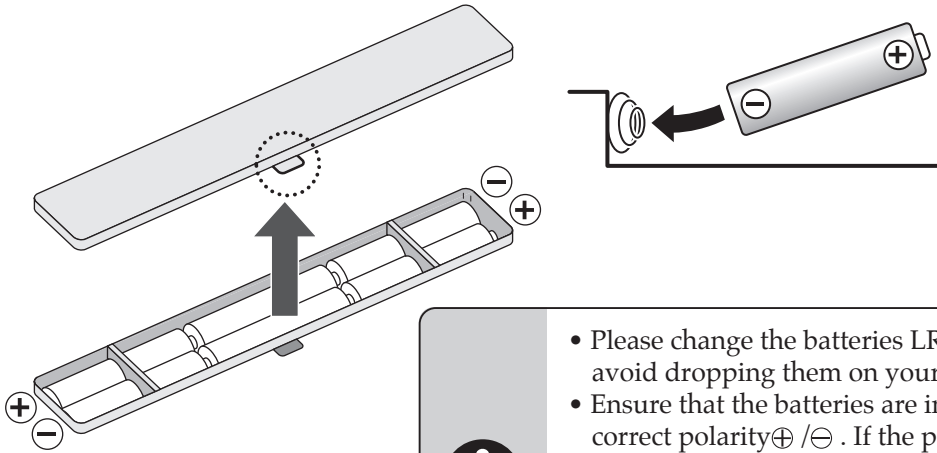

### Required

- Please change the batteries LR6 (AA) carefully to avoid dropping them on your feet.
- Ensure that the batteries are inserted with the correct polarity ⊕ / ⊖ . If the polarity is incorrect, then the batteries may leak and damage the product.
- When not in use for a long time, remove the batteries before storing the product.
- $\text{Lo}$  is displayed when battery power is running out. Promptly replace with six new batteries.



### Prohibited

- Do not use old batteries together with new batteries, or a mix of different types of batteries at the same time.
- Do not replace with wet hands. Do not allow water to contact or spill on the battery box.

## Using the AC adapter

- (1) Insert the AC adapter jack into the AC adapter inlet on the right side of the main unit.
- (2) Plug the AC adapter into the power outlet.

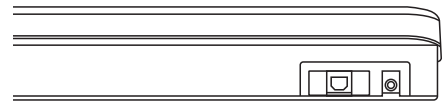

### Required

- This product must be used with the designated AC adapter.
- Please observe the following instructions for accurate measurement. Measurement may not be possible on the unstable environment. During weight measurement, please don't touch any connecting cable such as an AC Adapter cable and PC communication cable to avoid causing unstable scale installation.

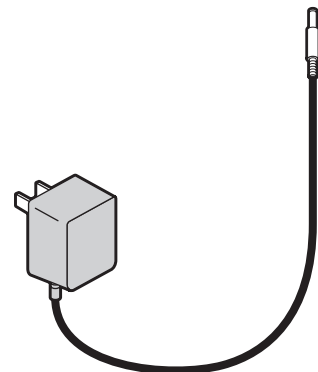

# Power Supply

## When turn on the power

Press ON/OFF to turn on the power.

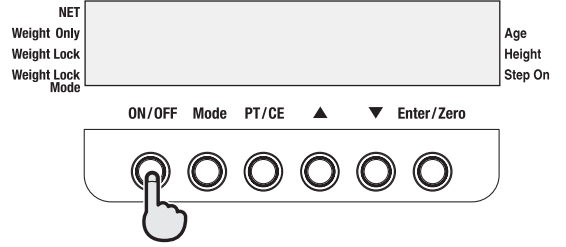

## When turn off the power

Press ON/OFF to turn off the power.

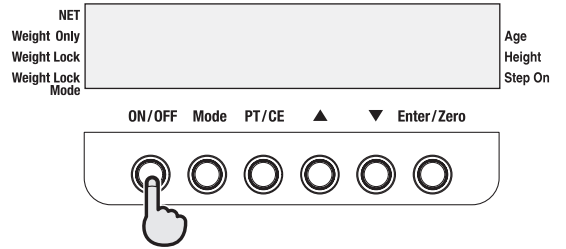

# Emergency Shutdown

Pull out the batteries or AC adapter in case of an emergency.

## When using the batteries

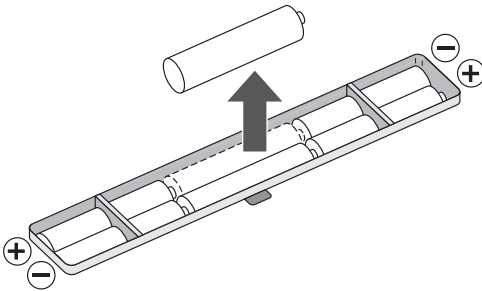

## When using the AC Adapter

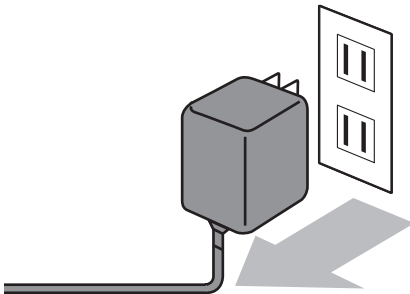

For emergency, keep clear around the outlet during operating this product.

## Call up the setting mode

**1** Press ON/OFF to turn on the power.

**2** Press Enter/Zero for 1 second.

SET 0 is displayed.

**3** Select the setting items by using ▲ or ▼.  
Press Enter/Zero .

- SET 0 Check the software version.
- SET 1 Set ON/OFF of the beep sound.  
(0: off, 1: on, default: 1 on)
- SET 2 Set ON/OFF of the athlete selection.  
(0: off, 1: on, default: 1 on)
- SET 3 Set the automatic determination time when inputting.  
(input range 0–9 seconds, default: 5 seconds)  
\* “0” automatic determination function deactivate.
- SET 4 Set the automatic power off time.  
(0, 5, 10, 30, 60 minutes, default: 5 minutes)  
\* “0” automatic power off function deactivate.
- SET 5 Set the unit.  
(0: kg, 1: lb, default: 1 lb)

**4** Input the setting value by using ▲ or ▼.  
Press Enter/Zero .

**5** Press ON/OFF to turn the power off.

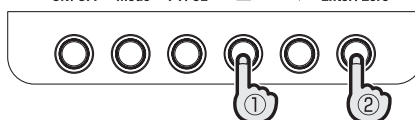
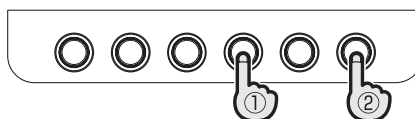
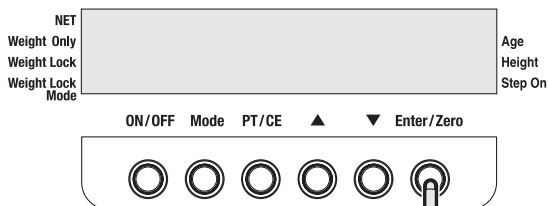

# How to Use (Mode Selection)

**1** Press ON/OFF to turn on the power.

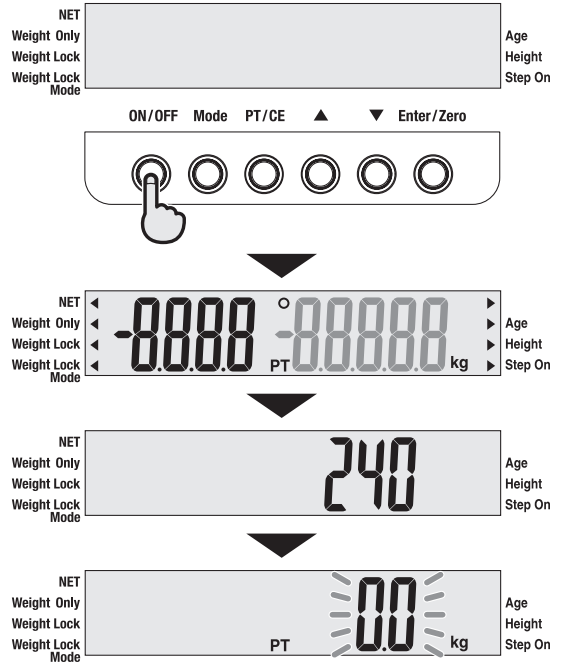

Model name is displayed.

00 is displayed.  
The product will be booted by  
Body Composition Mode.

**2** Select the mode by Mode.

Body Composition Mode (P.13)

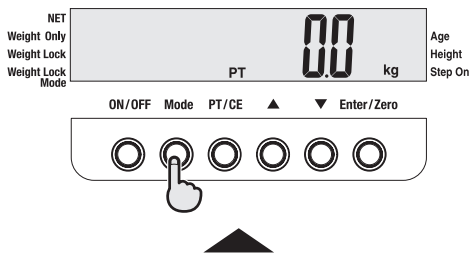

Scale Mode (P.16)

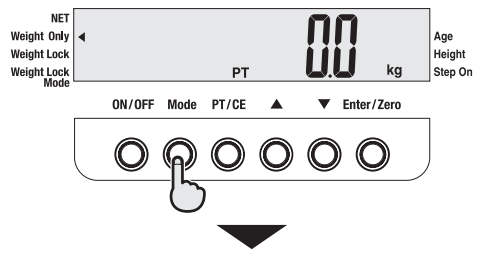

Scale: BMI Mode (P.18)

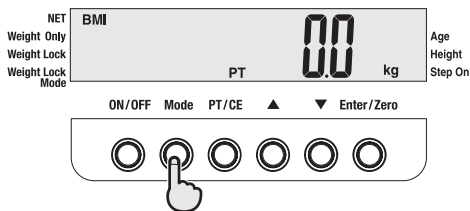

Scale: Weight Lock Mode (P.17)

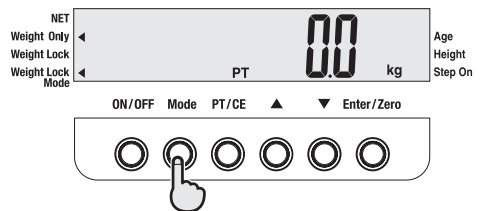

**3** Press Enter/Zero.

# How to Use (Body Composition Mode)

**1** Press ON/OFF to turn on the power.

**2** Check that the Body Composition Mode is selected (  P.12).

**3** Input the clothes weight by using ▲ or ▼.

Press Enter/Zero .

\* PT/CE → clear the input.

**4** Select the body type and gender by using ▲ or ▼.

Press Enter/Zero .

\* PT/CE → clear the input.

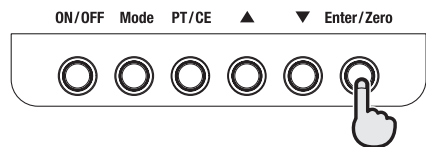
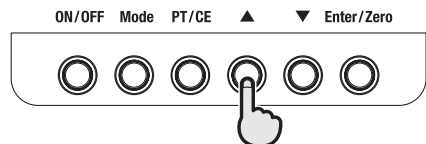
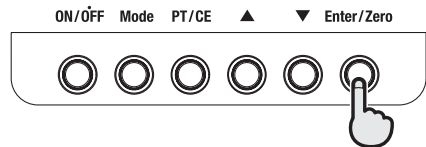
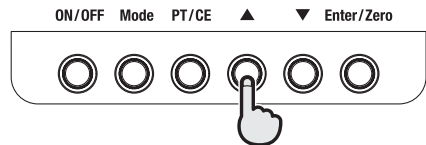
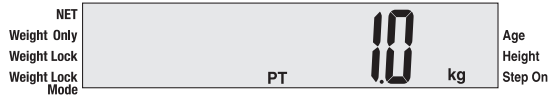
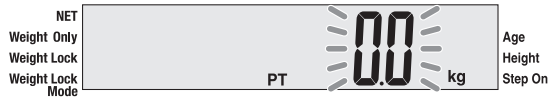

# How to Use (Body Composition Mode) (Continue)

**5** Input the age by using ▲ or ▼.

Press Enter/Zero .

\* PT/CE → return to previous status.

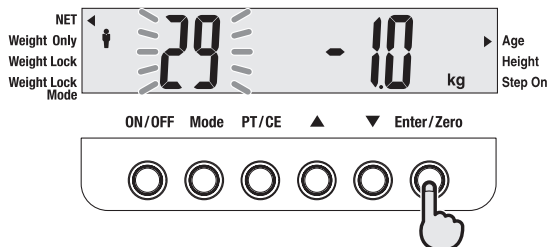
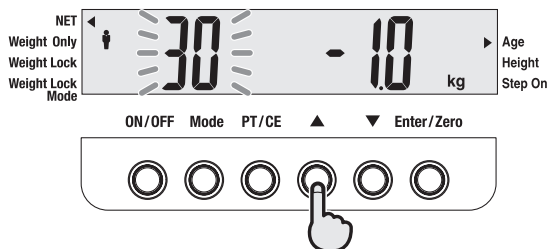

**6** Input the height by using ▲ or ▼.

Press Enter/Zero .

\* PT/CE → return to previous status

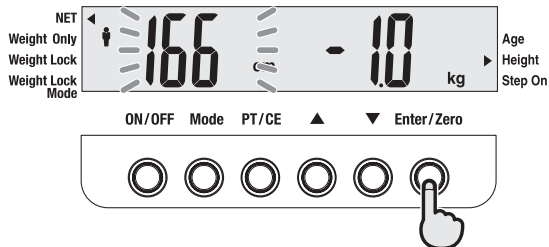
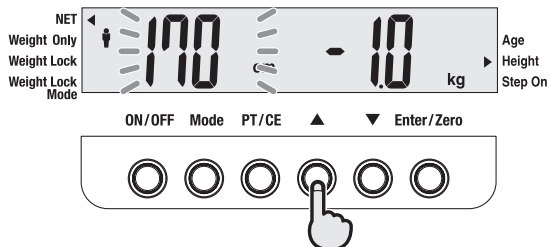

# How to Use (Body Composition Mode)

**7** Step on the platform with bare feet, after "Step On" flashing.

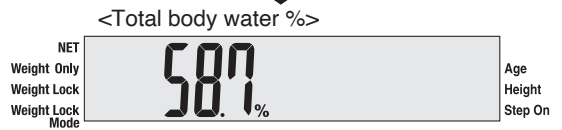
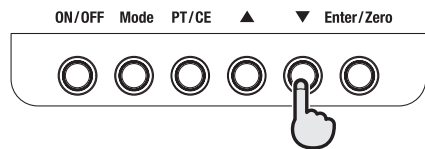
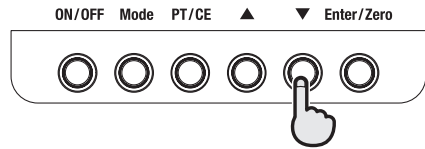
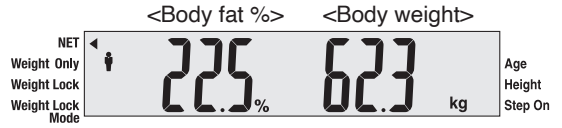
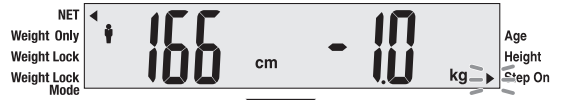

**8** Measurement completion.

\* PT/CE , Enter/Zero → return to previous status.

# How to Use (Scale Mode)

**1** Press ON/OFF to turn on the power.

**2** Select the Scale Mode.  
Check that the "Weight Only" lights up  
(☞ P.12).

**3** Input the clothes weight by using ▲ or ▼.

Press Enter/Zero .

\* PT/CE → return to previous status

**4** Step on the platform, after "Step On" flashing.

**5** Measurement completion.

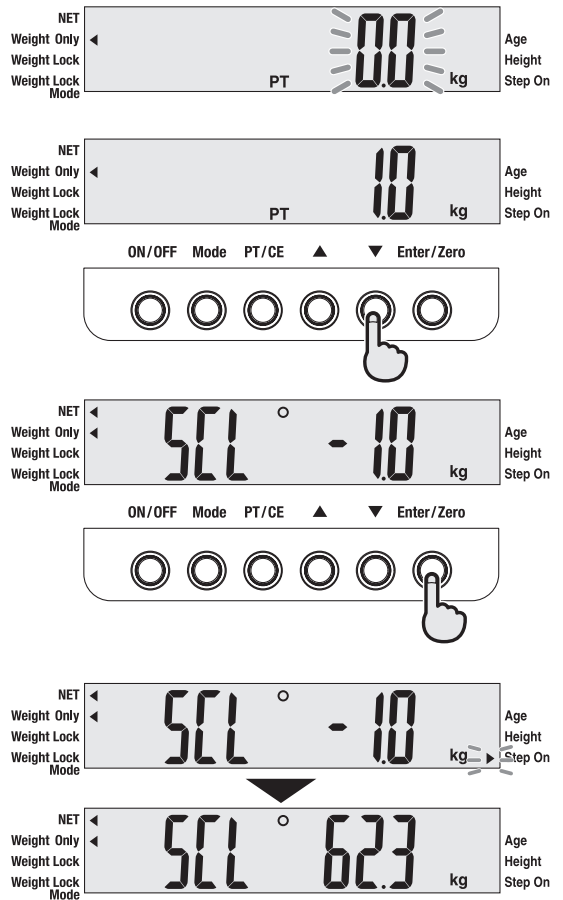



# How to Use (Scale: Weight Lock Mode)

## Activation of Weight Lock Mode

- 1** Press ON/OFF to turn on the power.
- 2** Select the Scale: Weight Lock Mode.  
Check that the "Weight Only"  
"Weight Lock Mode" lights up (  P.12).
- 3** Input the clothes weight by using ▲ or ▼.

Press Enter/Zero.

\* PT/CE → clear the input.

- 4** Step on the platform, after "Step On" flashing.

- 5** Measurement completion.

\* Enter/Zero → Clear the displayed result.

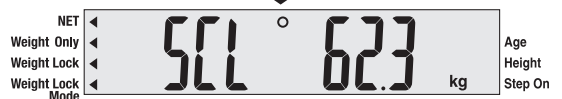
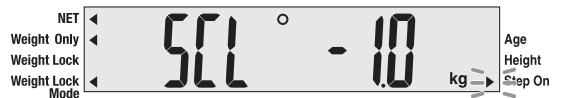
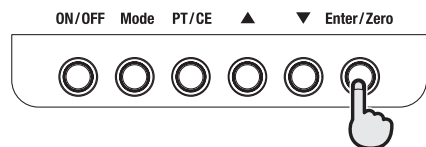
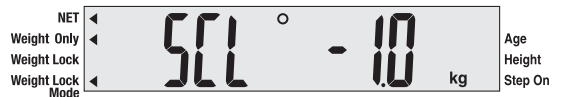
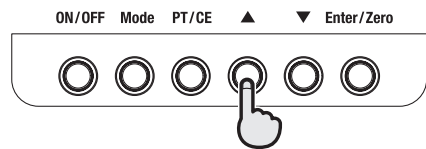
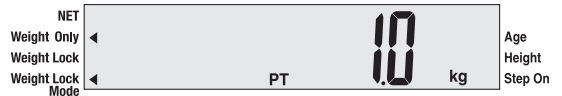
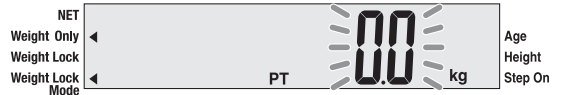

# How to Use (Scale: BMI Mode)

**1** Press ON/OFF to turn on the power.

**2** Select the Scale: BMI Mode.  
Check that the "BMI" is displayed (☞ P.12).

**3** Input the clothes weight by using ▲ or ▼.

Press Enter/Zero .

\* PT/CE → clear the input.

**4** Input the height weight by using ▲ or ▼.

Press Enter/Zero .

\* PT/CE → return to previous status



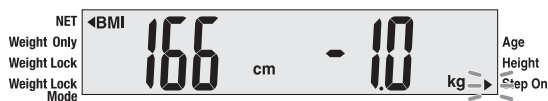
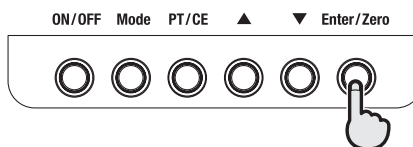
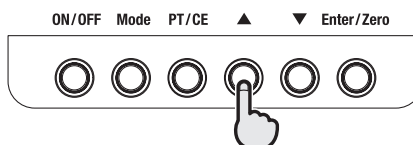
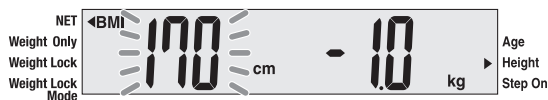
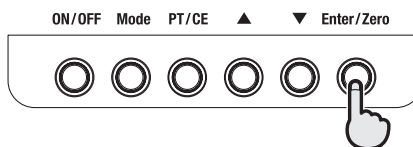
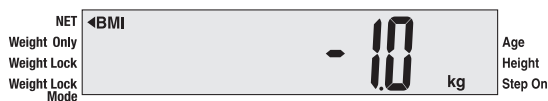
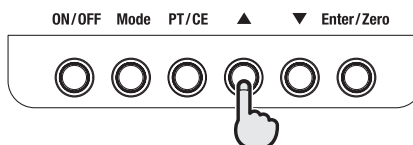
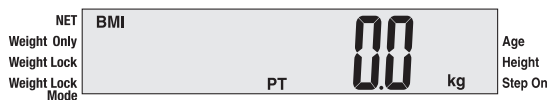
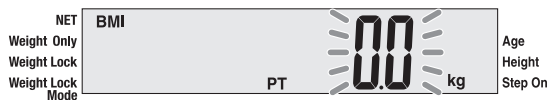

**5** Step on the platform, after "Step On" flashing.

**6** Measurement completion.

\* PT/CE, Enter/Zero → Clear the displayed result.

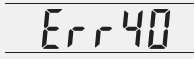

- Please check the following before asking for repair.

Symptom		Please check
How to measure	<p>Impedance measurement error</p>  	<ul style="list-style-type: none"> <li>· Measure with bare feet.</li> <li>· If the soles of your feet are dry, use a dropper to drop about 0.5mL of water on the electrodes before measurement.</li> <li>· Check the input information.</li> </ul>
	<p>Zero point error</p> 	<ul style="list-style-type: none"> <li>· Turn off the power, and remove the items on the platform and turn on the power again, and then redo the measurement.</li> </ul>
	<p>The measured weight is not stable.</p>	<ul style="list-style-type: none"> <li>· Is it installed at a place with vibrations?</li> <li>· Is the platform inclined? ⇒ Keep the platform horizontal.</li> <li>· Is anything caught in the gaps of the platform? ⇒ Remove anything caught in the gaps.</li> </ul>
Display	<p>Nothing is displayed even after turning on the power.</p>	<ul style="list-style-type: none"> <li>· Check that the power supply is connected correctly.</li> </ul>
	 <p>is displayed.</p>	<ul style="list-style-type: none"> <li>· The weight to measure exceeds the measurement range.</li> </ul>

### Note

In the case that an error is displayed other than the above, turn off the power once, and then measure again.

If the same error is displayed repeatedly, contact our customer service center.

# Technical Notes

## Body composition measurement by the BIA method.

### - Introduction

This equipment provides estimated values for each measured value of body fat percentage, fat mass, fat-free mass, muscle mass and bone mass by the DXA method, estimated value for the total body water measured value by the dilution method and estimated value for the visceral fat rating by MRI method using the Bioelectrical Impedance Analysis (BIA method).

For measurement, a mode must be selected based on body type.

1) Standard (for 5–99 years of age)

2) Athletic (for Athletic persons who exercise considerably more than non-athlete)

Making a distinction by body type in the measurement mode produces more reliable body composition measurements for athletic persons, whose body compositions differ from those of average persons.

### - Principles of body composition measurement

BIA is a means of measuring body composition – fat mass, predicted muscle mass, etc. – by measuring bioelectrical impedance in the body. Fat within the body allows almost no electricity to pass through, while electricity passes rather easily through water, much of which is found in muscles. The degree of difficulty with which electricity passes through a substance is known as the electrical resistance, and the percentage of fat and other body constituents can be inferred from measurements of this resistance.

The TANITA Body Composition Analyzer measures body composition using a constant current source with a high frequency current (50 kHz, 90  $\mu$ A). The 8 electrodes are positioned so that electric current is supplied from the electrodes on the tips of the toes of both feet, and voltage is measured on the heel of both feet. The current flows into the upper limbs or lower limbs, depending on the body part(s) to be measured.

### - What is the DXA method?

DXA was originally designed to measure bone mineral content, but in the full-body scan mode the body fat percentage, fat mass, and fat free mass of individual body parts (arms, legs, trunk) can also be measured. The image below shows one example of body composition measurement results obtained by DXA.

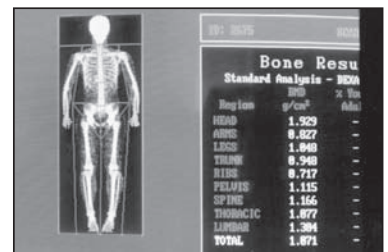

Body composition measurement results obtained by DXA (Lunar Co., Ltd; DPX-L)

### - What is dilution method?

In the dilution method, a labeled substance for a known amount is given and the concentration in equilibrium diffusing evenly is measured to obtain the total amount of the solvent that dilutes the labeled substance.

To measure the total body water (TBW), deuterium oxide (D<sub>2</sub>O) is generally used as the labeled substance. Deuterium oxide uses the overall total body water as dilution space so the total body water can be obtained. To obtain the extracellular fluid amount, sodium bromide (NaBr) is used as a labeled substance. Bromine (Br) is said to not enter the inside of cells, and uses extracellular fluid as the dilution space.

# Various criteria

## - What is body fat percentage?

Body fat percentage is the amount of body fat as a proportion of your body weight.

Reducing excess levels of body fat has shown to reduce the risk of certain conditions such as high blood pressure, heart disease, diabetes and cancer. The chart below shows the healthy ranges for body fat.

Body Fat Ranges for Standard Children<sup>1,2</sup>  
Body Fat Ranges for Standard Adults<sup>3</sup>

<sup>1</sup> Susan Jebb et al. *Obesity Research*(02) 2004;12:A156-157  
"New Body Fat Reference Curves for children"

<sup>2</sup> HD McCarthy et al. *Int J Obes* 2006; 30: 598-602  
"Body Fat Reference Curves for Children."

<sup>3</sup> Gallagher D et al. *Am J Clin Nutr* 2000;72:694-701.  
"Healthy percentage body fat ranges: an approach for developing guidelines based on body mass index."

		Underfat								Healthy								Overfat								Obese																				
Female Age	5	1	2	3	4	5	6	7	8	9	10	11	12	13	14	15	16	17	18	19	20	21	22	23	24	25	26	27	28	29	30	31	32	33	34	35	36	37	38	39	40	41	42	43	44	45
	6	1	2	3	4	5	6	7	8	9	10	11	12	13	14	15	16	17	18	19	20	21	22	23	24	25	26	27	28	29	30	31	32	33	34	35	36	37	38	39	40	41	42	43	44	45
	7	1	2	3	4	5	6	7	8	9	10	11	12	13	14	15	16	17	18	19	20	21	22	23	24	25	26	27	28	29	30	31	32	33	34	35	36	37	38	39	40	41	42	43	44	45
	8	1	2	3	4	5	6	7	8	9	10	11	12	13	14	15	16	17	18	19	20	21	22	23	24	25	26	27	28	29	30	31	32	33	34	35	36	37	38	39	40	41	42	43	44	45
	9	1	2	3	4	5	6	7	8	9	10	11	12	13	14	15	16	17	18	19	20	21	22	23	24	25	26	27	28	29	30	31	32	33	34	35	36	37	38	39	40	41	42	43	44	45
	10	1	2	3	4	5	6	7	8	9	10	11	12	13	14	15	16	17	18	19	20	21	22	23	24	25	26	27	28	29	30	31	32	33	34	35	36	37	38	39	40	41	42	43	44	45
	11	1	2	3	4	5	6	7	8	9	10	11	12	13	14	15	16	17	18	19	20	21	22	23	24	25	26	27	28	29	30	31	32	33	34	35	36	37	38	39	40	41	42	43	44	45
	12	1	2	3	4	5	6	7	8	9	10	11	12	13	14	15	16	17	18	19	20	21	22	23	24	25	26	27	28	29	30	31	32	33	34	35	36	37	38	39	40	41	42	43	44	45
	13	1	2	3	4	5	6	7	8	9	10	11	12	13	14	15	16	17	18	19	20	21	22	23	24	25	26	27	28	29	30	31	32	33	34	35	36	37	38	39	40	41	42	43	44	45
	14	1	2	3	4	5	6	7	8	9	10	11	12	13	14	15	16	17	18	19	20	21	22	23	24	25	26	27	28	29	30	31	32	33	34	35	36	37	38	39	40	41	42	43	44	45
	15	1	2	3	4	5	6	7	8	9	10	11	12	13	14	15	16	17	18	19	20	21	22	23	24	25	26	27	28	29	30	31	32	33	34	35	36	37	38	39	40	41	42	43	44	45
	16	1	2	3	4	5	6	7	8	9	10	11	12	13	14	15	16	17	18	19	20	21	22	23	24	25	26	27	28	29	30	31	32	33	34	35	36	37	38	39	40	41	42	43	44	45
	17	1	2	3	4	5	6	7	8	9	10	11	12	13	14	15	16	17	18	19	20	21	22	23	24	25	26	27	28	29	30	31	32	33	34	35	36	37	38	39	40	41	42	43	44	45
	18	1	2	3	4	5	6	7	8	9	10	11	12	13	14	15	16	17	18	19	20	21	22	23	24	25	26	27	28	29	30	31	32	33	34	35	36	37	38	39	40	41	42	43	44	45
	19	1	2	3	4	5	6	7	8	9	10	11	12	13	14	15	16	17	18	19	20	21	22	23	24	25	26	27	28	29	30	31	32	33	34	35	36	37	38	39	40	41	42	43	44	45
	20-39	1	2	3	4	5	6	7	8	9	10	11	12	13	14	15	16	17	18	19	20	21	22	23	24	25	26	27	28	29	30	31	32	33	34	35	36	37	38	39	40	41	42	43	44	45
	40-59	1	2	3	4	5	6	7	8	9	10	11	12	13	14	15	16	17	18	19	20	21	22	23	24	25	26	27	28	29	30	31	32	33	34	35	36	37	38	39	40	41	42	43	44	45
	60-	1	2	3	4	5	6	7	8	9	10	11	12	13	14	15	16	17	18	19	20	21	22	23	24	25	26	27	28	29	30	31	32	33	34	35	36	37	38	39	40	41	42	43	44	45

		0%					10%					20%					30%					40%																								
Male Age	5	1	2	3	4	5	6	7	8	9	10	11	12	13	14	15	16	17	18	19	20	21	22	23	24	25	26	27	28	29	30	31	32	33	34	35	36	37	38	39	40	41	42	43	44	45
	6	1	2	3	4	5	6	7	8	9	10	11	12	13	14	15	16	17	18	19	20	21	22	23	24	25	26	27	28	29	30	31	32	33	34	35	36	37	38	39	40	41	42	43	44	45
	7	1	2	3	4	5	6	7	8	9	10	11	12	13	14	15	16	17	18	19	20	21	22	23	24	25	26	27	28	29	30	31	32	33	34	35	36	37	38	39	40	41	42	43	44	45
	8	1	2	3	4	5	6	7	8	9	10	11	12	13	14	15	16	17	18	19	20	21	22	23	24	25	26	27	28	29	30	31	32	33	34	35	36	37	38	39	40	41	42	43	44	45
	9	1	2	3	4	5	6	7	8	9	10	11	12	13	14	15	16	17	18	19	20	21	22	23	24	25	26	27	28	29	30	31	32	33	34	35	36	37	38	39	40	41	42	43	44	45
	10	1	2	3	4	5	6	7	8	9	10	11	12	13	14	15	16	17	18	19	20	21	22	23	24	25	26	27	28	29	30	31	32	33	34	35	36	37	38	39	40	41	42	43	44	45
	11	1	2	3	4	5	6	7	8	9	10	11	12	13	14	15	16	17	18	19	20	21	22	23	24	25	26	27	28	29	30	31	32	33	34	35	36	37	38	39	40	41	42	43	44	45
	12	1	2	3	4	5	6	7	8	9	10	11	12	13	14	15	16	17	18	19	20	21	22	23	24	25	26	27	28	29	30	31	32	33	34	35	36	37	38	39	40	41	42	43	44	45
	13	1	2	3	4	5	6	7	8	9	10	11	12	13	14	15	16	17	18	19	20	21	22	23	24	25	26	27	28	29	30	31	32	33	34	35	36	37	38	39	40	41	42	43	44	45
	14	1	2	3	4	5	6	7	8	9	10	11	12	13	14	15	16	17	18	19	20	21	22	23	24	25	26	27	28	29	30	31	32	33	34	35	36	37	38	39	40	41	42	43	44	45
	15	1	2	3	4	5	6	7	8	9	10	11	12	13	14	15	16	17	18	19	20	21	22	23	24	25	26	27	28	29	30	31	32	33	34	35	36	37	38	39	40	41	42	43	44	45
	16	1	2	3	4	5	6	7	8	9	10	11	12	13	14	15	16	17	18	19	20	21	22	23	24	25	26	27	28	29	30	31	32	33	34	35	36	37	38	39	40	41	42	43	44	45
	17	1	2	3	4	5	6	7	8	9	10	11	12	13	14	15	16	17	18	19	20	21	22	23	24	25	26	27	28	29	30	31	32	33	34	35	36	37	38	39	40	41	42	43	44	45
	18	1	2	3	4	5	6	7	8	9	10	11	12	13	14	15	16	17	18	19	20	21	22	23	24	25	26	27	28	29	30	31	32	33	34	35	36	37	38	39	40	41	42	43	44	45
	19	1	2	3	4	5	6	7	8	9	10	11	12	13	14	15	16	17	18	19	20	21	22	23	24	25	26	27	28	29	30	31	32	33	34	35	36	37	38	39	40	41	42	43	44	45
	20-39	1	2	3	4	5	6	7	8	9	10	11	12	13	14	15	16	17	18	19	20	21	22	23	24	25	26	27	28	29	30	31	32	33	34	35	36	37	38	39	40	41	42	43	44	45
	40-59	1	2	3	4	5	6	7	8	9	10	11	12	13	14	15	16	17	18	19	20	21	22	23	24	25	26	27	28	29	30	31	32	33	34	35	36	37	38	39	40	41	42	43	44	45
	60-	1	2	3	4	5	6	7	8	9	10	11	12	13	14	15	16	17	18	19	20	21	22	23	24																					

# Technical Notes (Continue)

---

## - What is total body water percentage?

---

**Total Body Water Percentage is the total amount of fluid in a person's body expressed as a percentage of their total weight.**

Water plays a vital role in many of the body's processes and is found in every cell, tissue and organ. Maintaining a healthy total body water percentage will ensure the body functions efficiently and will reduce the risk of developing associated health problems.

Your body water levels naturally fluctuate throughout the day and night. Your body tends to be dehydrated after a long night and there are differences in fluid distribution between day and night. Eating large meals, drinking alcohol, menstruation, illness, exercising, and bathing may cause variations in your hydration levels.

Your body water percentage reading should act as a guide and should not be used to specifically determine your absolute recommended total body water percentage. It is important to look for long-term changes in total body water percentage and maintain a consistent, healthy total body water percentage.

Drinking a large quantity of water in one sitting will not instantly change your water level. In fact, it will increase your body fat reading due to the additional weight gain. Please monitor all readings over time to track the relative change.

Every individual varies but as a guide the average total body water percentage ranges for a healthy adult are:

**Female:** 45 to 60%

**Male:** 50 to 65%

**Source:** Based on TANITA's Internal Research

### Note

The total body water percentage will tend to decrease as the percentage of body fat increases. A person with a high percentage of body fat may fall below the average body water percentage. As you lose body fat the total body water percentage should gradually move towards the typical range given above.

## - What is visceral fat rating?

---

**This feature indicates the rating of visceral fat in your body.**

Visceral fat is the fat that is in the internal abdominal cavity, surrounding the vital organs in the trunk (abdominal) area. Research shows that even if your weight and body fat remains constant, as you get older the distribution of fat changes and is more likely to shift to the trunk area especially post menopause. Ensuring you have healthy levels of visceral fat may reduce the risk of certain diseases such as heart disease, high blood pressure, and the onset of type 2 diabetes.

The TANITA Body Composition Analyzer will provide you with a visceral fat rating from 1 to 59.

### Rating from 1 to 12

Indicates you have a healthy level of visceral fat. Continue monitoring your rating to ensure that it stays within the healthy range.

### Rating from 13 to 59

Indicates you have an excess level of visceral fat. Consider making changes in your lifestyle possibly through diet changes or increasing exercise.

Source: 1) TANITA Institute Contract Study. Algorithm Development for Estimating Visceral Fat Rating. SB Heymsfield MD. Columbia University College of Physicians and Surgeons 2004.

2) Wang, Z., et al. Japanese-American Differences in Visceral Adiposity and a Simplified Estimation Method for Visceral Adipose Tissue. North American Association for the Study of Obesity. Annual Meeting. Abstract 518-P. 2004

### Note

- Even if you have a low body fat rate, you may have a high visceral fat level.
- For medical diagnosis, consult a physician.

---

## - What is basal metabolic rate (BMR)?

---

### **What is BMR?**

Your Basal Metabolic Rate (BMR) is the minimum level of energy your body needs when at rest to function effectively including your respiratory and circulatory organs, neural system, liver, kidneys, and other organs. You burn calories when sleeping.

About 70% of calories consumed every day are used for your basal metabolism. In addition, energy is used when doing any kind of activity. However, the more vigorous the activity is the more calories are burned. This is because skeletal muscle (which accounts for approximately 40% of your body weight) acts as your metabolic engine and uses a large amount of energy. Your basal metabolism is greatly affected by the quantity of muscles you have, therefore increasing your muscle mass will help increase your basal metabolism.

By studying healthy individuals, scientists have found that as people age, their metabolic rate changes. Basal metabolism rises as a child matures. After a peak at the age of 16 or 17, it typically starts to decrease gradually.

Having a higher basal metabolism will increase the number of calories used and help to decrease the amount of body fat. A low basal metabolic rate will make it harder to lose body fat and overall weight.

### **How does a TANITA body composition analyzer calculate BMR?**

The basic way of calculating Basal Metabolic Rate BMR is a standard equation using weight and age. TANITA has conducted in-depth research into the relationship of BMR and body composition giving a much more accurate and personalized reading for the user based on the impedance measurement. This method has been medically validated using indirect calorimetry (measuring the breath composition).\*

\* Reliability on equation for Basal Metabolic Rate: At 2002 Nutrition Week: A Scientific and Clinical Forum and Exposition  
Title: International Comparison: Resting Energy Expenditure Prediction Models: The American Journal of Clinical Nutrition

---

## - What is metabolic age?

---

**This feature calculates your BMR and indicates the average age associated with that type of metabolism.**

If your BMR Age is higher than your actual age, it is an indication that you need to improve your metabolic rate. Increased exercise will build healthy muscle tissue, which will improve your metabolic age.

You will obtain a reading between 12 and 90. Under 12 will be displayed as "12" and over 90 displayed as "90".

# Technical Notes (Continue)

## - What is muscle mass?

**This feature indicates the weight of muscle in your body.**

The muscle mass displayed includes the skeletal muscles, smooth muscles (such as cardiac and digestive muscles) and the water contained in these muscles.

Muscles play an important role as they act as an engine in consuming energy. As your muscle mass increase, your energy consumption increases helping you reduce excess body fat levels and lose weight in a healthy way.

## - What is bone mass?

**This feature indicates the amount of bone (bone mineral level, calcium or other minerals) in the body.**

Research has shown that exercise and the development of muscle tissue are related to stronger, healthier bones. While bone structure is unlikely to make noticeable changes in a short period, it is important that you develop and maintain healthy bones by having a balanced diet and plenty of exercise. People worried about bone disease should consult their physician. People who suffer from osteoporosis or low bone densities due to advanced age, young age, pregnancy, hormonal treatment or other causes, may not get accurate estimations of their bone mass.

Below is the result of estimated dry bone mass of persons aged 20 to 40, who are said to have the largest amounts of bone masses, by weight. (Source: TANITA Body Weight Science Institute)

Please use the below charts as a guide to compare your bone mass reading.

### Women: Average of estimated dry bone mass

Weight (lb)		
Less than 110 lb	110 lb to 165 lb	165 lb and up
4.3 lb	5.3 lb	6.5 lb

Weight (kg)		
Less than 50 kg	50 kg to 75 kg	75 kg and up
1.95 kg	2.40 kg	2.95 kg

### Men: Average of estimated dry bone mass

Weight (lb)		
Less than 143 lb	143 lb to 209 lb	209 lb and up
5.9 lb	7.3 lb	8.1 lb

Weight (kg)		
Less than 65 kg	65 kg to 95 kg	95 kg and up
2.66 kg	3.29 kg	3.69 kg

### Note

Persons described below may obtain varying readings and should take the values given for reference purposes only.

- Elderly persons - Women after menopause
- People receiving hormone therapy

“Estimated bone mass” is a value estimated statistically based on its correlation with the fat-free mass (tissues other than the fat). “Estimated bone mass” does not give a direct judgment on the hardness or strength of the bones or the risks of bone fractures. If you have concerns over your bones, you are recommended to consult a physician.



# Specifications

<b>Model</b>		DC-240	
<b>Power source</b>	<b>AC adapter</b>	Centre minus 9V DC	
	<b>Battery</b>	9V DC LR6 (AA)×6	
<b>Power Consumption</b>		0.5 W	
<b>Impedance Measurement</b>	<b>Measurement System</b>	Dual-frequency 4 electrodes	
	<b>Measurement Frequency</b>	5kHz/50kHz	
	<b>Measurement Current</b>	90 μA or less	
	<b>Measurement Range</b>	150–1000 Ω	
<b>Weight Measurement</b>	<b>Measurement System</b>	Strain Gauge Load Cell	
	<b>Maximum Capacity</b>	440 lb	200 kg
	<b>Minimum Graduation</b>	0.2 lb	0.1 kg
<b>Input Items</b>	<b>Clothes Weight</b>	0–44 lb / 0.2 lb increments	0–10 kg / 0.1 kg increments
	<b>Gender</b>	Female / Male	
	<b>Body Type</b>	Standard / Athletic	
	<b>Age</b>	5–99 years (Standard) / 18–99 years (Athletic)	
	<b>Height</b>	3 ft–7 ft 11.5 in / 0.5 in increments	90–249 cm / 1 cm increments
<b>Output Items (Display)</b>	<b>Weight</b>	0–440 lb / 0.2 lb increments	0–200.0 kg / 0.1 kg increments
	<b>Body Fat %</b>	3–75% / 0.1% increments	
	<b>BMI</b>	0.1 increments	
	<b>Total Body Water %</b>	15–85% / 0.1% increments	
<b>Interface Connections</b>		USB	
<b>Weight of Equipment</b>		10.0 lb	4.7 kg
<b>Size</b>		13.4×17.2×2.1 in	341×437×54 mm

- The product design and specifications may be changed at any time without prior notice.
- When age exceeds 99 years old, it is just for reference.

USA and Canada

## Federal Communications Commission and Canadian ICES Notice

This equipment has been tested and found to comply with the limits for a Class B digital device, pursuant to Part 15 of the FCC Rules and Canadian ICES-003. These limits are designed to provide reasonable protection against harmful interference in a residential installation. This equipment generates, uses and can radiate radio frequency energy and, if not installed and used in accordance with the instructions, may cause harmful interference to radio communications. However, there is no guarantee that interference will not occur in a particular installation. If this equipment does cause harmful interference to radio or television reception, which can be determined by turning the equipment off and on, the user is encouraged to try to correct the interference by one or more of the following measures:

- Reorient or relocate the receiving antenna.
- Increase the separation between the equipment and receiver.
- Connect the equipment into an outlet on a circuit different from that to which the receiver is connected.
- Consult the dealer or an experienced radio or television technician for help.

## Modifications

The FCC requires the user to be notified that any changes or modifications made to this device that are not expressly approved by TANITA Corporation may void the user's authority to operate the equipment.

## Manufacturer

### TANITA Corporation

1-14-2 Maeno-cho, Itabashi-ku,  
Tokyo 174-8630 Japan  
TEL: +81-(0)3-3968-7048  
www.tanita.co.jp

## EU Representative

### TANITA Europe B.V.

Hoogoorddreef 56-E, 1101 BE  
Amsterdam, the Netherlands  
TEL: +31-(0)20-560-2970  
FAX: +31-(0)20-560-2988  
www.tanita.eu

## TANITA Corporation of America, Inc.

2625 South Clearbrook Drive,  
Arlington Heights, Illinois 60005  
U.S.A.  
TEL: +1-847-640-9241  
FAX: +1-847-640-9261  
www.tanita.com

## TANITA Health Equipment H.K. Ltd.

Unit 301-303, Wing On Plaza, 3/F., 62  
Mody Road,  
Tsimshatsui East, Kowloon, Hong Kong  
TEL: +852-2834-3917  
FAX: +852-2838-8667  
www.tanita.asia

## TANITA (Shanghai) Trading Co., Ltd.

Room 8005, 877 Huai Hai Zhong Lu,  
Shanghai,  
The People's Republic of China  
TEL: +86-21-6474-6803  
FAX: +86-21-6474-7901  
www.tanita.com.cn