

# ELECTRONIC SCALE **WB-800 plus**

## Instruction manual

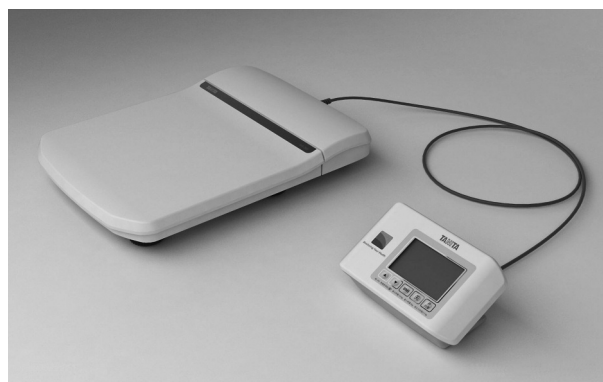

### <Usage Conditions>

Temperature Range for Use	: 41°F – 95°F / 5°C – 35°C
Relative Humidity	: 30% – 80% (without condensation)

### <Storage Conditions>

Temperature Range of Environment	: 14°F – 122°F / -10°C – 50°C
Range of Relative Humidity	: 10% – 90% (without condensation)

To avoid malfunctions, avoid storing the equipment where there is direct sunlight, significant temperature changes, the risk of dampness, a large amount of dust, in the vicinity of fires, or where there is the risk of receiving vibrations or shocks.



Please read this Instruction Manual carefully and keep it handy for future reference.

# 1. Table of Contents

2. Safety Notes .....	2	8. Operation .....	12
3. Part Names .....	6	9. Based on NIH/WHO BMI Guidelines .....	13
4. Assembly Instructions .....	8	10. Measuring height procedure .....	14
5. Functions .....	10	11. Output data format .....	16
6. Set up .....	10	12. Troubleshooting .....	18
7. Power supply .....	11	13. Specifications .....	19

# 2. Safety Notes

The following outlines precautionary measures to be taken to avoid injury to the users of this device and others, and to prevent damage to property. Please familiarize yourself with the contents to ensure the safe operation of this equipment.

 **Warning** Ignoring instructions highlighted with this mark could result in death or severe injury.

 **Caution** Ignoring instructions highlighted with this mark could result in injury or damage to property.



This mark indicates actions that are prohibited.



This mark indicates instructions that must always be adhered to.

## Warning

**Do not handle the plug with a wet hand.**  
Such action may result in electric shock, fire, or leakage.



**Keep this equipment away from flammable gas and oxygen rich environment.**

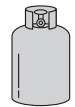

Prohibited

**No modification of this equipment is allowed.**  
There is a risk of electrocution or injury. Nor can precise analysis be guaranteed.

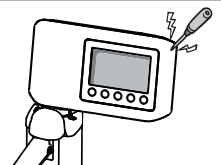

**Do not use double adapters.**  
May result in fire.

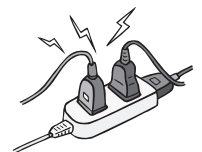

Always...

**Use only a correctly wired outlet.**  
Only genuine cables and equipments are allowed.

# **Caution**



Prohibited

**Keep away from water.**

**Do not jump on the equipment.**

**Do not insert fingers into gaps and holes.**

**Do not apply force to the display.**

The screen panel may break and cause injury.

**Assist persons with disabilities.**

Another person should assist persons with disabilities who may not be able to take a measurement alone.



Always...

**Be sure clean the scale platform with appropriate disinfectant after each use.**

**Stand clear of the subject during measurement to ensure accuracy.**

**Continually monitor both the subject and the equipment for anomalies.**

If an anomaly in the subject or equipment is discovered, take appropriate action, such as stopping the equipment, while ensuring the safety of the subject.

**Be sure to use the included AC adapter.**

**Unplug the AC cable from the equipment when moving it.**

**When not in use for a long time, unplug the AC Adapter from the wall socket.**

**Interpretation of analysis results (e.g. evaluation of measurements and formulation of exercise programmes based on results) must be performed by a professional.**

Weight loss measures and exercise based on self-analysis could be harmful to you health. Always follow the advice of a qualified professional.

# For Accurate Measurements

Eng



Always...

**Avoid measuring in multiple locations with greatly differing temperatures.**

This may cause inaccurate measurements. Allow the equipment to stand for at least 2 hours before using if it is moved to a new location with a temperature difference of 36°F / 20°C or more.

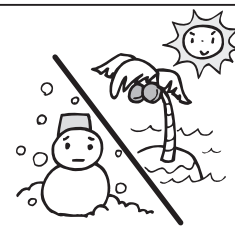

**Ensure the weighing platform is placed on a level and stable surface.**

**Avoid subjecting the equipment to excessive shocks or vibrations.**

**Use in a stable location.**

Errors in measurements may occur if the device is used in an unstable location.

# Scheduled Maintenance



Always...

**TANITA recommends that each facility conduct periodic checks of each unit.**

1. Check the following at least daily:
  - The unit is on a stable and level surface ie on a firm flooring, not on a thick carpet
2. Visually inspect the following at least weekly:
  - The display for any damage or contamination
  - All cables, cords, and connector ends for damage or contamination
  - All safety-related labeling for legibility
  - All accessories (sensors, electrodes, etc.) for wear or damage
3. Visually inspect the following at least monthly:
  - Screws on equipment

**Update settings, replace items, or call for service as necessary according to the results of the visual inspections. Do not use the unit if you see any signs of damage. Equipment that has been damaged must be checked for proper operation by qualified personnel before using again.**



### 3. Part Names

WB-800H plus

WB-800P plus

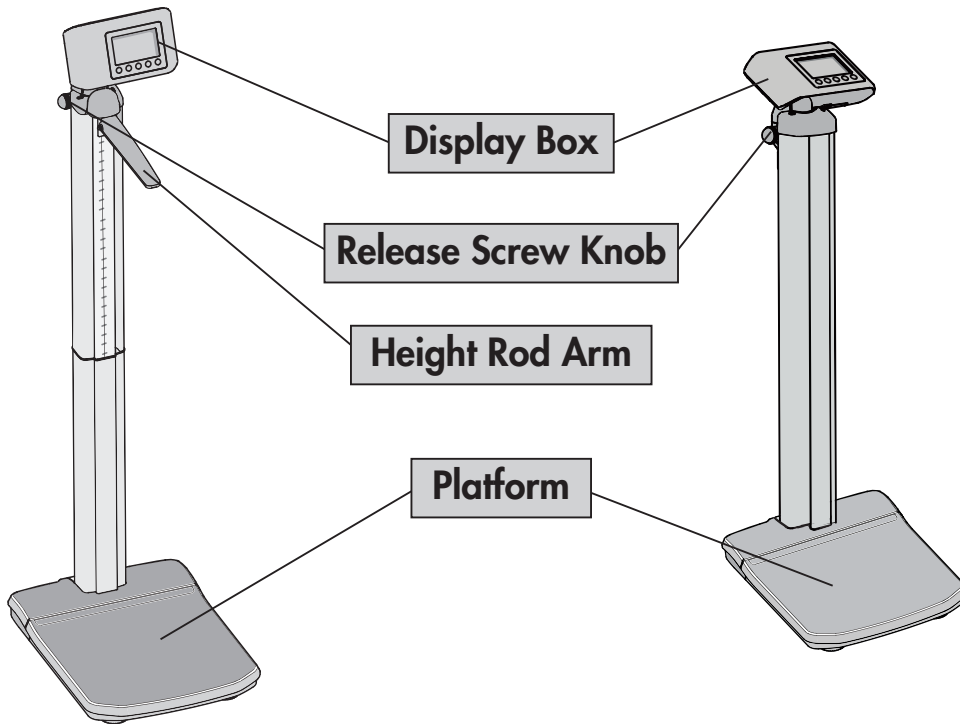

WB-800S plus

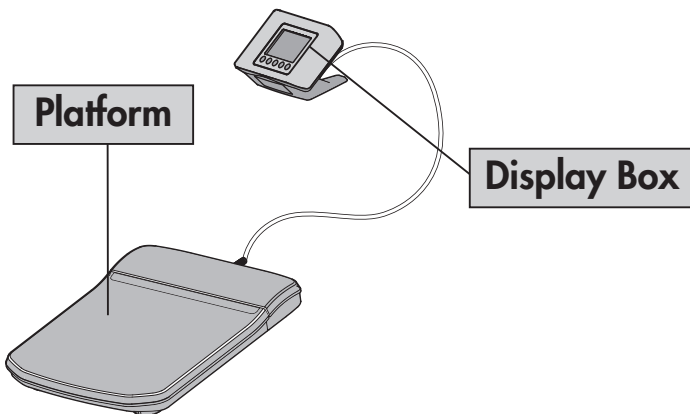

Display Box

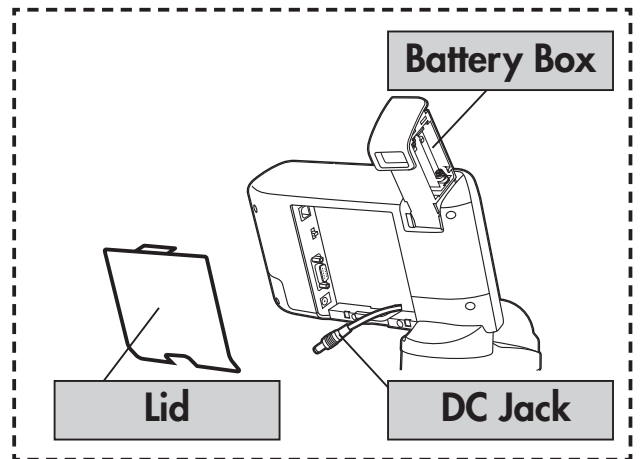

### Accessories

<WB-800S plus>

AC Adapter

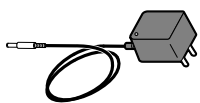

CD ROM  
(This Manual)

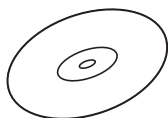

<WB-800H plus, WB-800P plus>

AC Adapter

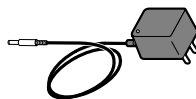

Back Cover

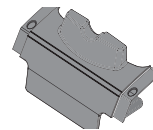

Front Cover

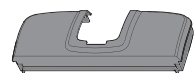

CD ROM (This Manual)



Screw x 4



## ■ Control Panel

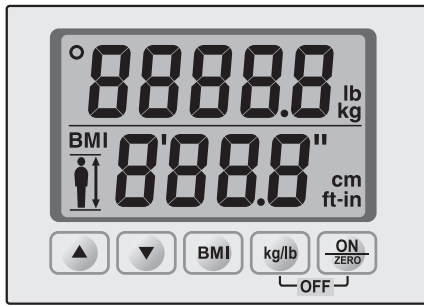

## ■ Symbols and their Meanings

<b>ON</b>	Display Unit On		Caution Refer to the attached notes.
<b>ZERO</b>	Zero reset		Output
<b>kg/lb</b>	Changing Measurement Units		Direct current
<b>BMI</b>	Select BMI mode		
<b>▲/▼</b>	Adjust height for BMI		
<b>OFF</b>	Display Unit Off		

## 4. Assembly Instructions

- ❶ Platform (fully assembled and pre-wired to display assembly)
- ❷ Cable (Platform side)
- ❸ Lower Pole Assembly
- ❹ Screw
- ❺ Cable (Cables) (Top Head Display Assembly Side)
- ❻ Top Head Display Assembly (fully assembled and pre-wired to platform)
- ❼ Back Cover
- ❽ Front Cover
- ❾ Top Height Rod Assembly (fully assembled with pivoting height measuring lever)
- ❿ Height Rod Arm
- ⓫ Lower Height Rod Assembly

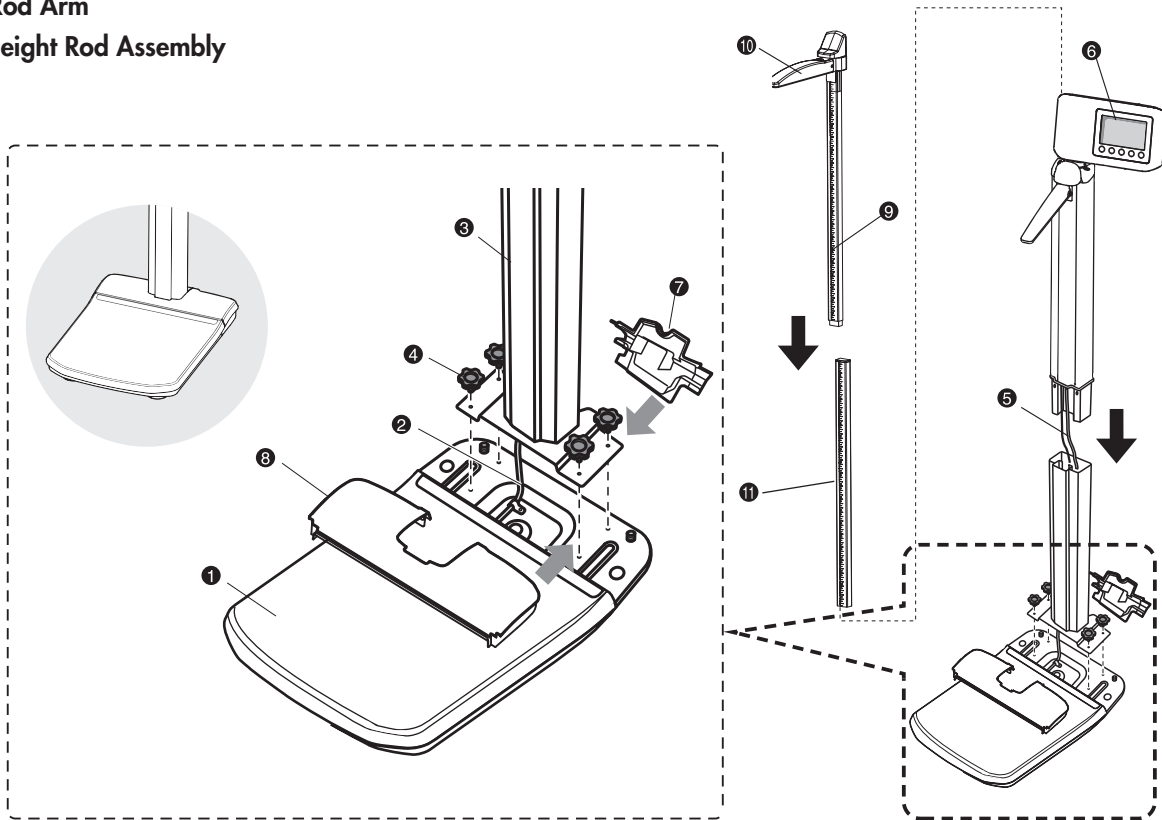



## For WB-800H plus

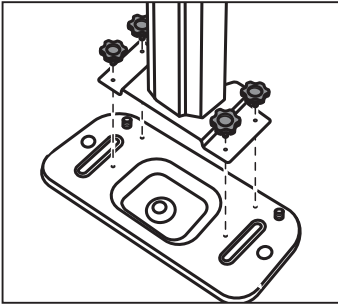

Install the lower pole into the platform using the four (4) screws.

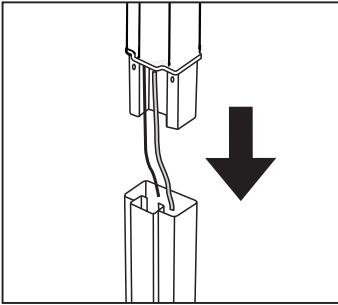

Assemble the top head display into the lower pole inserting the cable into lower pole.

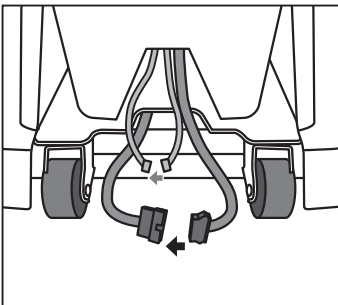

Connect the cables inside the bottom of the lower pole.

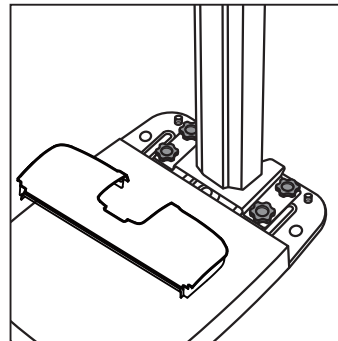
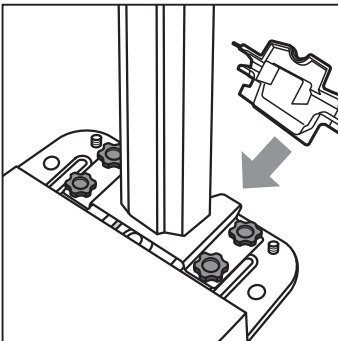

Attach the back cover and the front cover as shown.

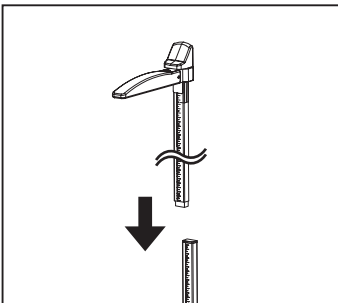

Push all the way down assembled the top height rod to the lower height rod opening on the pole.

## For WB-800P plus

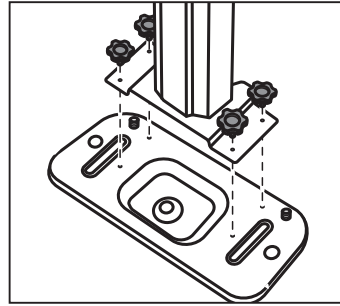

Install the lower pole into the platform using the four (4) screws.



Assemble the top head display into the lower pole inserting the cable into lower pole.

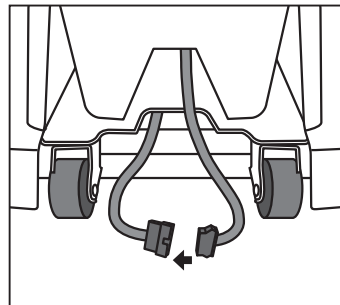

Connect the cable inside the bottom of the lower pole.

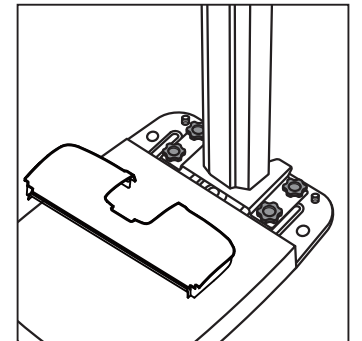
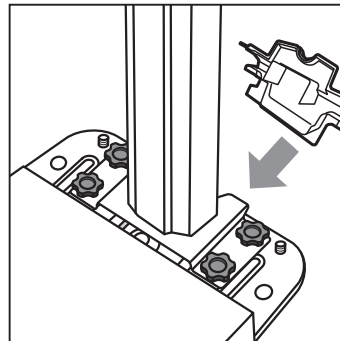

Attach the back cover and the front cover as shown.

## 5. Functions

### Automatic Power Off

This equipment has an automatic power off function that automatically turns off the power in order to reduce battery consumption.

If the display does not change for 30 seconds, the power will be automatically turned off.

## 6. Set up

### Flat and stable location

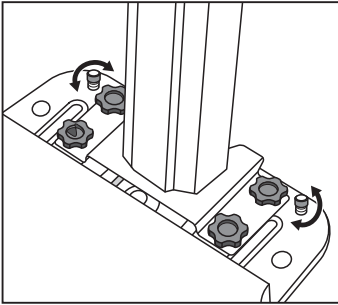

To obtain the highest level of accuracy, please make sure that all four (4) feet are touching on the floor evenly.

For further accuracy and security, please position the two (2) adjustable supporting feet on the platform (found under the front cover) until they just make contact with the floor (do not overextend)

- Do not position it anywhere that is subject to direct sunlight, near heating equipment, or directly in the path of an air conditioner outlet.
- Do not use it anywhere that is subject significant temperature change.
- Do not position it anywhere that it either damp or subject to high humidity.

**CAUTION** • Put the weighing platform on a flat, level surface.

### Angle Adjustment

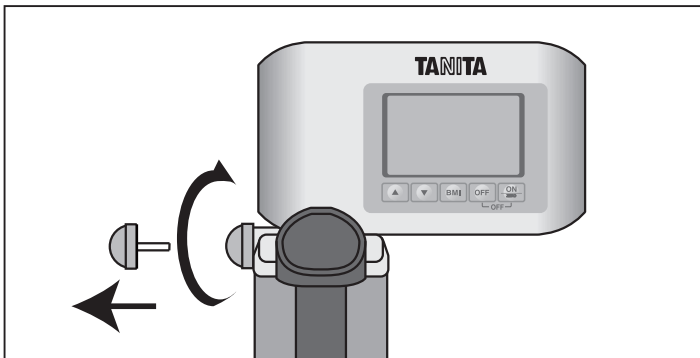

1) Fully release screw knob on the pole.

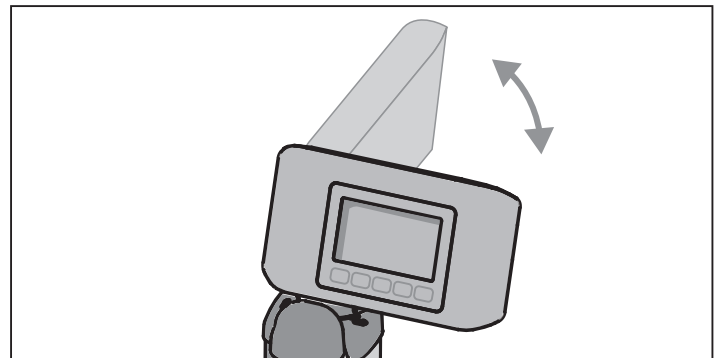

2) The display box could select at 90-degree 2 positions be sure to screw it tightly after setting the position.

## 7. Power supply

### ■ AC adapter

AC adapter is much preferable when the scale will be used continuously.

Eng

#### For WB-800H plus, WB-800P plus

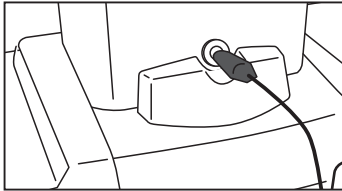

1) Plug on the AC adapter. Insert the AC adapter jack into the DC Jack on the back of the pole.

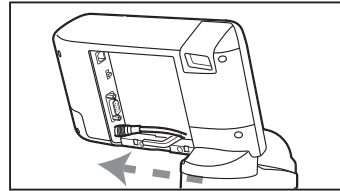

2) Insert the connector into the DC Jack on the back of the display box.

#### For WB-800S plus

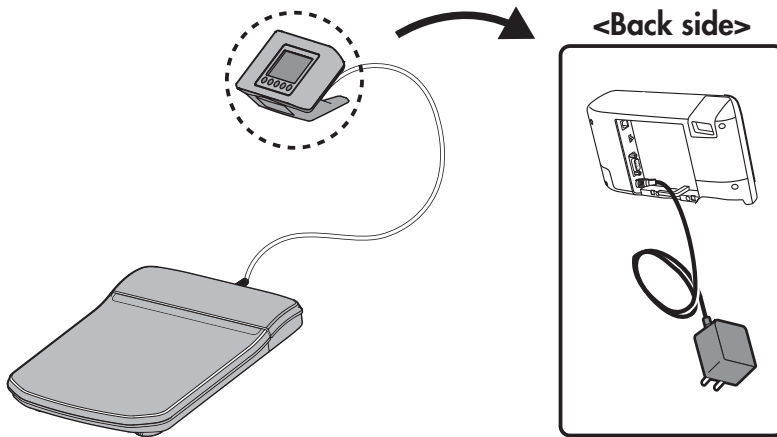

Plug on the AC adapter. Insert the AC adapter jack into the DC Jack on the back of the display box.

### ■ Batteries

#### For WB-800H plus, WB-800P plus

#### For WB-800S plus

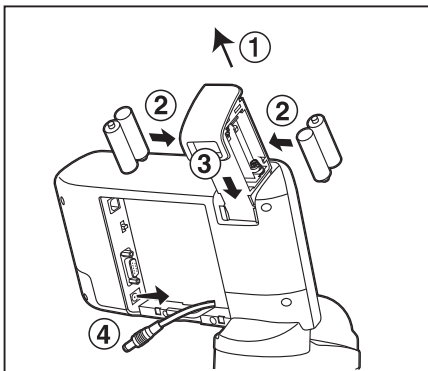

- 1) Pull up the battery case which located on top of display.
- 2) Ensure that the batteries are inserted with the correct polarity.
- 3) push down the battery case completely.
- 4) Unplug the DC connector on the back of the display box. (WB-800H plus and WB-800P plus only.)

\* Insert new batteries such that the negative terminals of the batteries are pushed up against the coils within the battery housing.

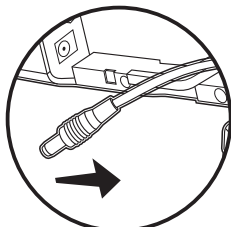

### ⚠ Caution

Unplug the DC connector. Or the scale wouldn't work.

## 8. Operation

Eng

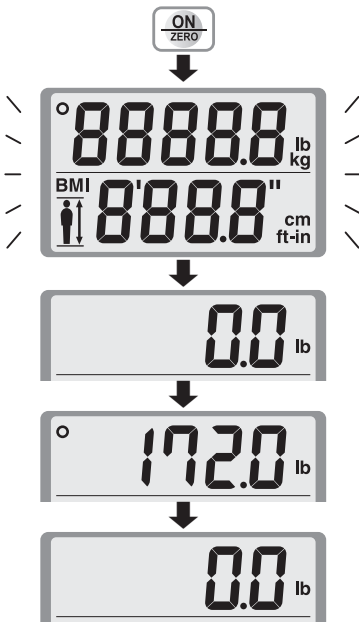

### 1. Standard Weighing Procedures

1) Turn on the power by pressing the key.

2) After all the segments flash, [0.0lb / 0.0kg] is displayed.



3) The person to be weighed should still in the middle of the platform.

4) The weight will be locked-in and displayed on the display. "○ (Hold)" sign will appear in the upper left corner of the display.

When the scale is connected to an external device, weight data will be exported at this time.

5) The scale will automatically shut off in 30 seconds.

**Note:** • Do not press the key while standing on the scale, as accurate measurement will not be possible.

### 2. BMI Weighing

1) Turn on the power by pressing the key.

2) After all the segments flash, [0.0lb / 0.0kg] is displayed.

3) The person to be weighed should still in the middle of the platform.

4) The weight will be locked-in and displayed on the display. "○ (Hold)" sign will appear in the upper left corner of the display.

5) Press the key (or ). The default height [5ft7.0in / 170cm] will be displayed.

6) Set the height with the key.

7) Once the height and weight have been established, press the key.

The weight and BMI calculation will then be displayed.

When the scale is connecting to an external device, weight, height and BMI data will be exported at this time.

8) The scale will automatically shut off in 30 seconds.

The setting of height for BMI is can be accomplished in any one of the following means by pressing the key (or ).

• Before stepping on the scale.

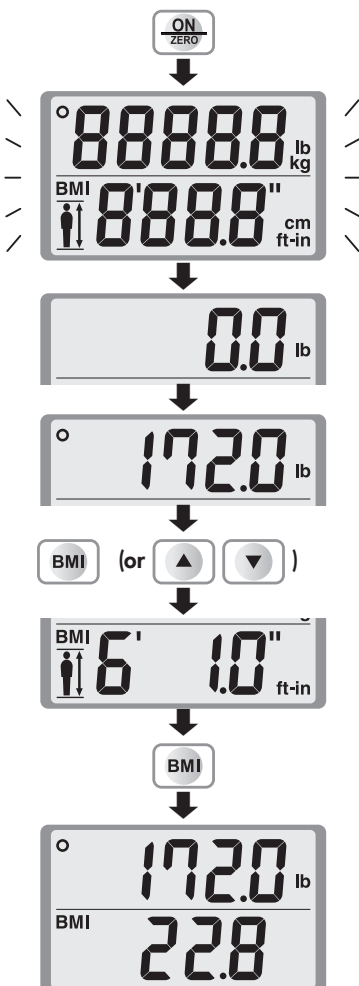

- After pressing the  key.
- After weight measurement while the weight result remains on the display.

### 3. Step on Function

The scale will turn on automatically when the user steps onto the platform.

**Note:**

- If the weight is less than 22lb / 10kg, the “Step-On” function will not work.
- If person less than 22lb / 10kg, press the  key manually to turn on the scale.
- If an item is placed on the scale while it is powered off, accurate measurement will not be possible and the Step on Function may not operate properly.

### 4. Changing Measurement Units

This function is used to change the measurement units on the display.

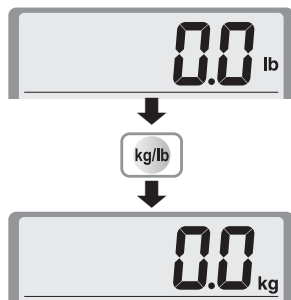

e.g. When change the unit “kg” to “lb”.

Press the  key.

The measure shifts from “kg” to “lb” and the measurement units change.

### 5. Power off

Press the  key and  key at the same time to turn off.

## 9. Based on NIH/WHO BMI Guidelines

Under Weight		BMI < 18.5
Normal Range		18.5 ≤ BMI < 25
Pre obese		25 ≤ BMI < 30
Obese	CLASS I	30 ≤ BMI < 35
Obese	CLASS II	35 ≤ BMI < 40
Obese	CLASS III	BMI ≥ 40

# 10. Measuring height procedure

## For WB-800H plus

The user should step on the platform without wearing shoes for accurate measurement.

Always have someone assist the user for accurate measurement.

1) **Adjust the Height Rod Arm position before the user steps on the platform. Place hand on the Height Rod Arm.**

If the subject is taller than 48" / 120 cm, pull the Height Rod Sliding Block and Height Rod Arm at the same time upward so that the arm is positioned higher than the subject's head.

If the subject is shorter than 48" / 120 cm, move the Height Rod Arm down.

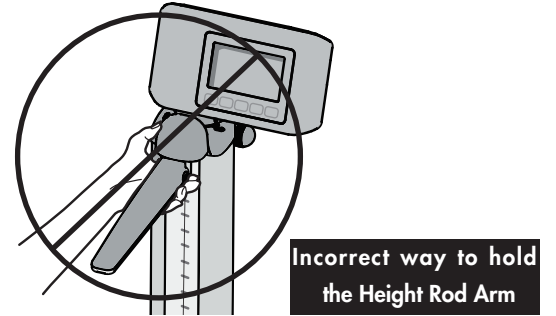
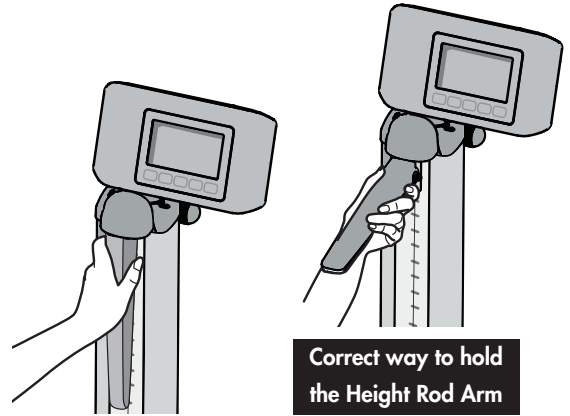

To avoid danger of breaking or coming loose, you must hold the height rod arm securely.

2) **Gently lower the Height Rod Arm until the Height Rod Arm touches the very top of the user's head.**

3) **Read the measurement.**

If the subject is taller than 48" / 120 cm, read the number just above the top of the Upper Pole Column (see example #1).

If the subject is shorter than 48" / 120cm, read the number below the Height Rod Arm (see example #2).

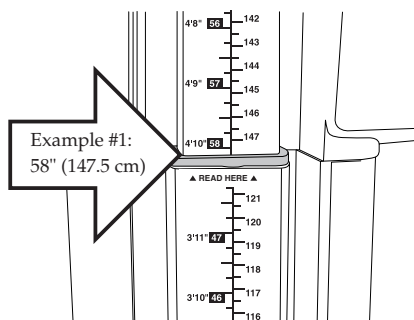
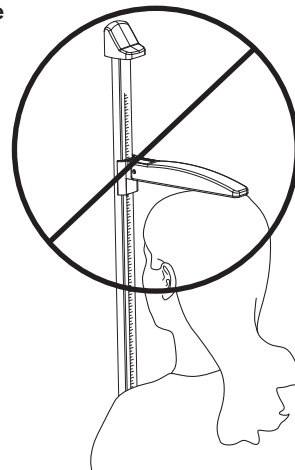
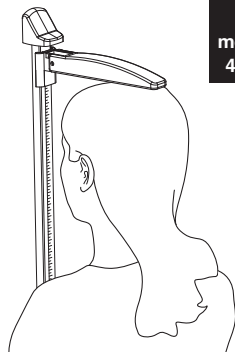

Reading the height measurement of 48" / 120cm or MORE

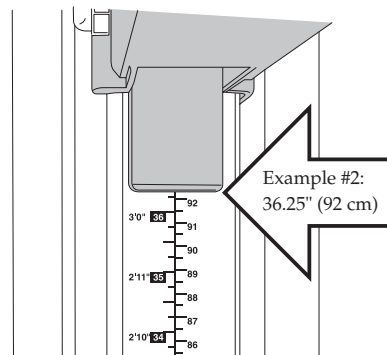

Reading the height measurement of 48" / 120cm or LESS



# 11. Output data format

Eng

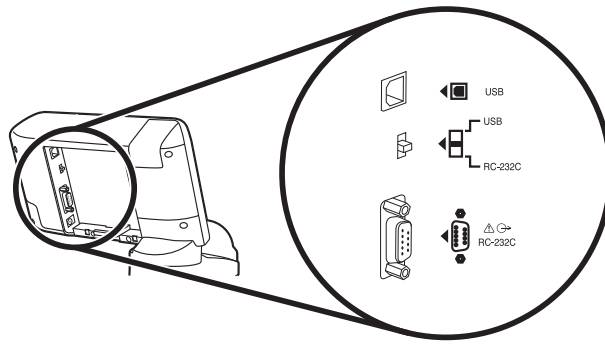

This section covers the exporting of data from the scale to an external device (e.g. PC) using a RS-232C and USB compliant signal.



- RS-232C and USB interface are for data OUTPUT ONLY!
- This scale is not capable of receiving instructions from an external device.

## Specifications

Communications standard	EIA RS-232C compatible	USB
Communications method	Asynchronous transaction	
Signal speed	9600 baud	
Data bit length	8 bits	
Parity	None	
Stop bit	1 bit	
Terminator	CR+LF	

### Note:

- An RS-232C connector (D sub 9-pin female) and USB connector (B-type 4-pin female) are located on the back of the display unit.
- Please provide your own cables as necessary as none are included.  
 RS-232C :Straight D sub 9-pin (male) – D sub 9-pin (female)  
 USB :A-type 4-pin (male) – B-type 4-pin (male)
- Select Switch : Please select which interface you would like to use

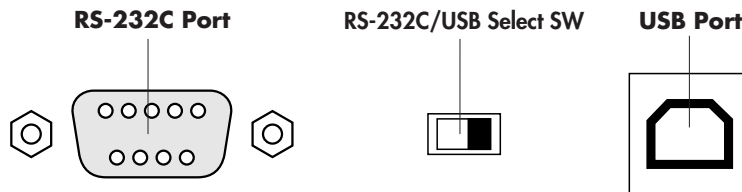

## Caution

If you want to use the USB output, you must install the necessary driver on to your PC, available to download from <http://www.tanita.com>

## Signal Line Name and Connection Method

Terminal no.	Signal name
1	
2	TXD
3	
4	
5	GND
6	
7	
8	
9	

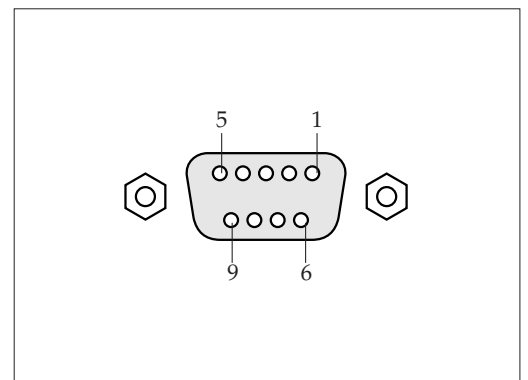



## Output data

Name of item	Header		Output data (ASCII code)		Pattern		
	kg mode	lb mode			BMI mode	Weight mode	
Control data	{ 0		Fix to 16	2 Bytes fixed	✓	✓	
Control data	~ 0		Fix to 1	1 Byte fixed	✓	✓	
Control data	~ 1		Fix to 1	1 Byte fixed	✓	—	
Control data	~ 2		Fix to 1	1 Byte fixed	✓	—	
Model	MO		"WB-380"	8 Byte fixed	✓	✓	
Height	Hm	Hf	xxx.x	x.xxx	4 – 6 bytes	✓	—
Weight	Wk	Wp	xxx.x		3 – 5 bytes	✓	✓
BMI	MI		xxx.x		3 – 5 bytes	✓	—
Checksum	CS		xx	2 Bytes fixed	✓	✓	

### Note:

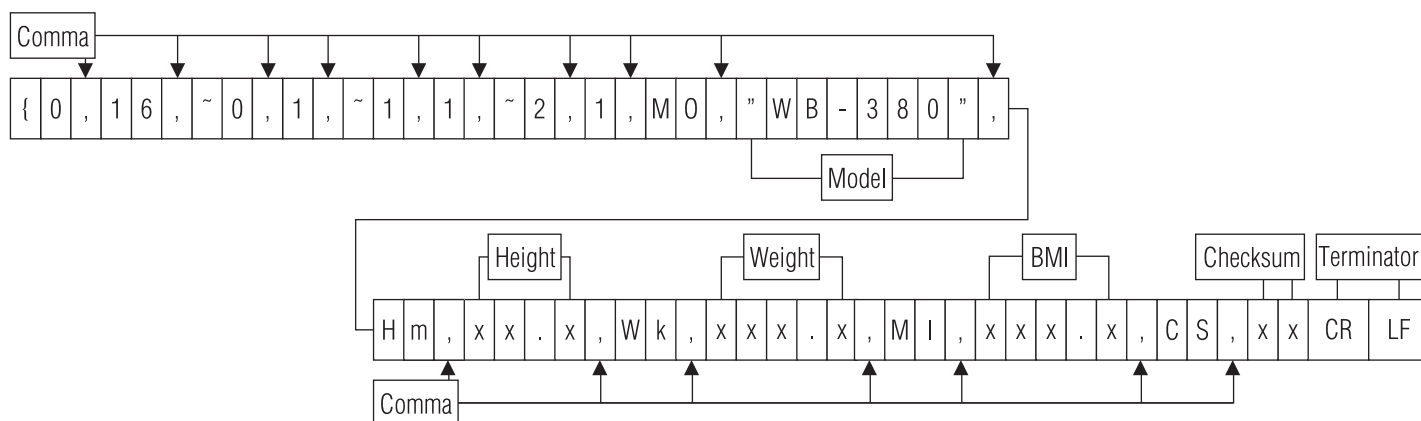

- The data are divided with commas (,) for each data.
- The terminator (end of the data) is CR (ASCII code 0DH), LF (ASCII code 0AH).
- The control data for the items 1 – 4 are for expansion. They are not used presently so the receiving side can ignore them.
- Because of its specifications, the scale will output an irrelevant signal approximately 0.1 second after data output. Make sure you ignore this signal and do not import it.

### [Output example]



## 12. Troubleshooting

If you are concerned that the scale may not be functioning correctly, please check the following point before requesting repairs.

Problem	Check Points
<b>Nothing is displayed when  key is pressed.</b>	<ul style="list-style-type: none"> <li>• Check the connection of the AC adapter jack to the DC jack, and the connection of the AC adapter plug to the power outlet.</li> <li>• The batteries may be weak. Try an AC adapter or new LR6 (AA) batteries.</li> <li>• Check the terminals of the batteries for contamination</li> <li>• Batteries — Unplug the DC connector on the back of the display box.</li> </ul>
<b>“Lo” is displayed.</b>	<p>The batteries are running out. Please replace them immediately or use the AC adapter.</p>
<b>Measurement is not accurate.</b>	<ul style="list-style-type: none"> <li>• Check that all feet of scale are stable and on a hard flat surface, carpeting depth should be kept to a minimum.</li> <li>• After having stepped down from the scale and pressed the  key, perform the measurement again.</li> <li>• Accurate measurement may be impossible if the product is used where there is excessive vibration.</li> </ul>
<b>The weight does not stabilize</b>	<ul style="list-style-type: none"> <li>• Are you moving during measurement?</li> <li>• Is the measured weight within the range of weight measurement?</li> <li>• Are you touching the height rod arm, switch, or another part during measurement?</li> </ul>
<b>“OL” is displayed</b>	<ul style="list-style-type: none"> <li>• The range of weight (660lb / 300kg) is exceeded.</li> </ul>
<b>“-OL” is displayed</b>	<ul style="list-style-type: none"> <li>• Was anything placed on the scale before measurement?</li> </ul>
<b>“Error” is displayed</b>	<ul style="list-style-type: none"> <li>• Check whether the cable between the platform and display is disconnected, cut, or pinched.</li> </ul>

# 13. Specifications

Model			WB-800 plus	
Weight Measurement	Measurement System		Strain Gauge Load Cell	
	Maximum Capacity / Minimum Graduation		660lb / 0.2lb	300kg / 0.1kg
	Range of Weight	Standard	0 - 660lb	0 - 300kg
		Step on	22 - 660lb	10 - 300kg
Height Measurement	Measurement System		Mechanical Height Rod	
	Range of Height		2ft 1in – 7ft	64cm – 214cm
Input Items	Height		2ft – 8ft 2in 0.5in increment	61cm- 250cm 1cm increments
Output Items	Display	Weight	660lb / 0.2lb	300kg / 0.1kg
		Height	2ft – 8ft 2in 0.5in increment	61cm- 250cm 1cm increments
		BMI	0.1 increments	
Size	Overall	WB-800H plus	W15.6 X D21.7 X H56.1 in Total 24.7lb	W395 x D552 x H1425 mm Total 11.2kg
		WB-800P plus	W15.6 X D23.4 X H47.1 in Total 22.1lb	W395 x D595 x H1196 mm Total 10.0kg
		WB-800S plus	W15.6 X D20.8 X H4.8 in Total 15.7lb	W395 x D529 x H123 mm Total 7.1kg
	Platform		W15.0 x D15.0 x H2.0 in	W380 x D380 x H51 mm
Display			Upper 5Digits and Lower 4Digits LCD Height of numerals 1in / 24mm	
Output Data Interface			RS-232C (D sub 9-pin Female connector) USB (B-type)	
Power Source			AC adapter (included) Center Minus	
Power Consumption			0.3 W max.	
Rated Power			DC 6V 500mA (LR6 - AA Alkaline Battery x 4)	
Temperature Range of usage			41°F - 95°F	5°C - 35°C

USA and Canada

### Federal Communications Commission and Canadian ICES Notice

This equipment has been tested and found to comply with the limits for a Class B digital device, pursuant to Part 15 of the FCC Rules and Canadian ICES-003. These limits are designed to provide reasonable protection against harmful interference in a residential installation. This equipment generates, uses and can radiate radio frequency energy and, if not installed and used in accordance with the instructions, may cause harmful interference to radio communications. However, there is no guarantee that interference will not occur in a particular installation. If this equipment does cause harmful interference to radio or television reception, which can be determined by turning the equipment off and on, the user is encouraged to try to correct the interference by one or more of the following measures:

- Reorient or relocate the receiving antenna.
- Increase the separation between the equipment and receiver.
- Connect the equipment into an outlet on a circuit different from that to which the receiver is connected.
- Consult the dealer or an experienced radio or television technician for help.

### Modifications

The FCC requires the user to be notified that any changes or modifications made to this device that are not expressly approved by Tanita Corporation may void the user's authority to operate the equipment.



This device features radio interference suppression in compliance with EC Regulation 2004/108/EC

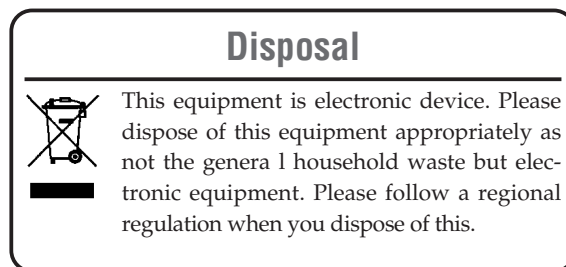

<U.S.A representative>

## TANITA Corporation of America, Inc.

2625 South Clearbrook Drive, Arlington Heights, Illinois 60005, U.S.A. TEL: 1-847-640-9241 FAX: 1-847-640-9261 <http://www.tanita.com>

<Manufacturer>

## TANITA Corporation

1-14-2, Maeno-cho, Itabashi-ku, Tokyo 174-8630, Japan TEL: +81 (0) 3-3968-7048 FAX: +81 (0) 3-3967-3766 <http://www.tanita.co.jp>

### TANITA Europe B.V.

Hoogoorddreef 56-E,  
1101 BE Amsterdam, the Netherlands  
TEL: 31-20-560-2970  
FAX: 31-20-560-2988  
<http://www.tanita.eu>

### TANITA Health Equipment H.K.LTD.

Unit 301-303, Wing On Plaza, 3/F., 62 Mody Road,  
Tsimshatsui East, Kowloon, Hong Kong  
TEL: +852-2834-3917  
FAX: +852-2838-8667  
[www.tanita.asia](http://www.tanita.asia)

### TANITA India Private Limited

A-502, Mittal Commercial, Off. M.V. Road (Andheri Kurla Road),  
Marol, Andheri-East, Mumbai 400 059 INDIA  
TEL: +91-22-3192-6107  
FAX: +91-22-2859-9143  
[www.tanita.co.in](http://www.tanita.co.in)

### TANITA (Shanghai) Trading Co., Ltd.

Room 8005, 877 Huai Hai Zhong Lu, Shanghai,  
The People's Republic of China  
TEL: +86-21-6474-6803  
FAX: +86-21-6474-7901  
[www.tanita.com.cn](http://www.tanita.com.cn)