

BODY COMPOSITION ANALYZER

DC-13CU

Instruction Manual

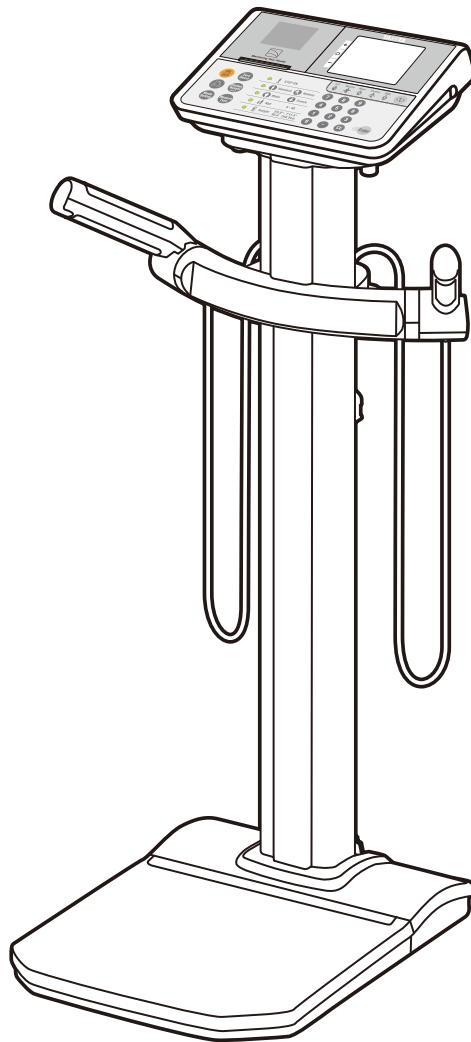

<Usage Conditions>

Temperature Range	: 41°F to 95°F/5°C to 35°C
Relative Humidity Range	: 30% to 80% (non-condensing)
Max Altitude	: 6,500ft ASL (2,000m ASL)
Atmospheric Pressure Range	: 86kPa to 106kPa

<Storage Conditions>

Temperature Range	: 14°F to 140°F/-10°C to 60°C
Relative Humidity Range	: 10% to 90% (non-condensing)
Atmospheric Pressure Range	: 70kPa to 106kPa

To avoid malfunctions, avoid storing the equipment in a place with direct sunlight, significant temperature changes, a risk of dampness, a large amount of dust or a risk of vibration or impact, or in the vicinity of flames.



Please read this Instruction Manual carefully and keep it for future reference.

Intended Use

TANITA Body Composition Analyzers have been clinically proven to be accurate, reliable and provide highly repeatable results. Our Analyzers are used worldwide by health, research and medical professionals primarily in the following fields:

- medical screening and health assessments of adults and children
- monitoring the progress of weight loss during medical treatment relating to lifestyle diseases such as diabetes, hyperlipidemia, bariatric surgery, hypertension and fatty liver disease.
- monitoring increases of muscle mass, reduction of body fat and hydration levels as part of a fitness or training program
- assessing the true effectiveness of nutrition and physical activity programs where body mass index cannot identify key changes in body composition
- collating subject data for large cohort research studies

The TANITA Body Composition Analyzer is indicated for use in the measurement of weight and impedance, and the estimation of body mass index (BMI), total body fat percent and weight, total body water percent and weight, total body muscle mass, physique rating, bone mass, visceral fat rating with healthy range, basal metabolic rate (BMR), and fat free mass (FFM), using BIA (Bioelectrical Impedance Analysis).

The device is indicated for use for healthy children 5 to 17 years old and healthy adults with active, moderately active, to inactive lifestyles.

Efficacy

This product has been specifically designed to be simple to use and required no additional user assistance to take a measurement.

Measurements can be taken in under 30 seconds for maximum convenience.

Contents

Before Use

For Your Safety	4
Checking the Contained Items	8
Positioning the Scale/Setting up the Mat	9
Part Names & Connection Procedure	10
Setting the Thermal Paper Roll	13
Setting an SD Card	14
Power Supply	15
Settings	16

How to Use

Taking a Measurement	18
Body Composition Mode.....	18
Measurement Results	20
Scale Mode	22
Output and Storage of Measurement Results	23
General Instructions for Body Composition Measurement	23
Select Printing Data	24
Printing Data	24
Lists of Contents of the Print Item Preset	25
In the Case to Select the Print Item Preset	26
Reading Stored Measurement Result Data	27
Data Output	28
Data Storage	28

If Necessary

Troubleshooting	29
Specifications	30

For Your Safety

en

Before Use

This section explains precautionary measures to be taken to avoid injury to the users of this equipment and others, and to prevent damage to property. Please familiarise yourself with this information to ensure safe operation of this equipment.



Warning

Failure to follow instructions highlighted with this mark could result in death or severe injury.



Caution

Failure to follow instructions highlighted with this mark could result in injury or damage to property.



Prohibited

This mark indicates actions that are prohibited.



Required

This mark indicates instructions that must always be followed.



Warning

This equipment must not be used on subjects with pacemakers or other electrical implants.

This equipment passes a weak electrical current through the body which could interfere with and cause the malfunction of electrical medical implants, with serious consequences.



Prohibited

Do not handle the plug with wet hands.

This may result in electric shock, fire, or current leakage.



Do not modify this equipment.

There is a risk of electrocution or injury, and precise analysis cannot be guaranteed.



Do not use multiple adapters.

This may result in fire.

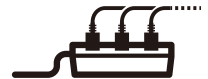

Do not use the equipment if you have any kind of wound or inflammation on any part of your body that comes into direct contact with the equipment.

Caution



Prohibited

Do not allow the equipment to get wet.

Avoid using on subjects with allergies to metals.

Allergic reactions may be caused by the stainless steel used in the electrodes of this equipment.

Do not jump on the equipment.

Do not tilt the equipment.

Do not use this equipment near other products that emit electromagnetic waves.

Do not insert fingers into any of the gaps or holes.

Do not apply force to the display.

The screen may break and cause injury.

Do not place items sensitive to magnetic forces near the equipment.

The magnet of the impedance meter may corrupt data on devices such as USB memory sticks if these are placed near the equipment.

Assist persons with disabilities.

Another person should assist persons with disabilities who may not be able to take a measurement alone.



Required

Clean the equipment after each use.

Wipe off the equipment if dust accumulates or it becomes dirty.

Stand clear of the subject during measurement to ensure accuracy.

Continually monitor both the subject and the equipment for anomalies.

If an anomaly in the subject or equipment is discovered, take appropriate action, such as stopping the equipment, while ensuring the safety of the subject.

Use the included AC cable.

Do not lean against the equipment.

Unplug the AC cable from the equipment when moving it.

Interpretation of analysis results (e.g. evaluation of measurements and formulation of exercise programs based on results) must be performed by a professional.

Weight loss measures and exercise based on self-analysis could be harmful to your health. Always follow the advice of a qualified professional.

This equipment is designated a Class B IT device (mainly for systems intended to be used in indoor environments) and is CE (EMC) certified, but it may affect devices that are sensitive to electromagnetic waves.

For Your Safety (continued)

en

Before Use



For Accurate Measurements



Prohibited

Avoid measuring after strenuous exercise.

This may cause inaccurate measurements. Please take measurements after sufficient rest.



Avoid measuring after over-eating or over-drinking, or when severely dehydrated.

This may cause inaccurate measurements. For greater accuracy, avoid using directly after waking up. Use at the same time of day each time, at least three hours after the last meal.



Ensure arms are not touching sides during measurement. If necessary, place a dry towel between arm and side.

Do not take measurements while using transmitting devices such as mobile phones, as these may affect readings.



Required

Use the equipment under the same conditions and in the same position as much as possible for accurate tracking of changes.

Readings are affected by the level of hydration and position of the body. Please use at the same time of day each time, under the same conditions and in the same body position.



Avoid measuring in multiple locations with greatly differing temperatures.

This may cause inaccurate measurements. Allow the equipment to stand for at least 2 hours before using if it is moved to a new location with a temperature difference of 36°F/20°C or more.



Place palms and fingers in the correct positions on the electrodes when measuring.

Improper contact between the hands and electrodes may cause the displayed fat percentage to be lower than the actual percentage, or cause an error.

Hold onto the grip. Be sure to wash your hands first.

Having dirty hands will cause inaccurate measurements.

Do not sit or bend the elbows or knees.

This causes inaccurate measurements.

Do not move during measurement.

This causes inaccurate measurements.

Use in a stable location.

Errors in measurements may occur if the equipment is used in an unstable location.

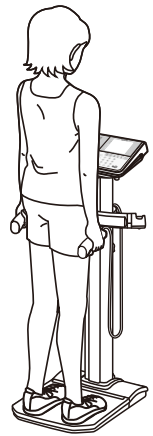

Note

For people to whom any of the following apply, changes in measurement values should be referred to as a reference.

- People with metal implants
- People taking medications that induce changes in body water (e.g. diuretics, etc.)
- People who are pregnant, on dialysis or experiencing any swelling. The reliability of body fat percentages may decrease.

Scheduled Maintenance

TANITA recommends that each facility conduct periodic checks of each unit.

1. Check the following at least daily:
 - The unit is on a stable and level surface on a firm flooring, not on a thick carpet
 - Date and time settings
2. Visually inspect the following at least weekly:
 - The display for any damage or contamination
 - All cables, cords, and connector ends for damage or contamination
 - All safety-related labeling for legibility
 - All accessories (electrodes, etc.) for wear or damage
3. Visually inspect the following at least monthly:
 - Mounting screws

Update settings, replace items, or call for service as necessary according to the results of the visual inspections. Do not use the unit if you see any signs of damage. Equipment that has been damaged must be checked for proper operation by qualified personnel before using again.

Incorrect Ways to Measure



With bent elbows and wrists



With skin to skin contact

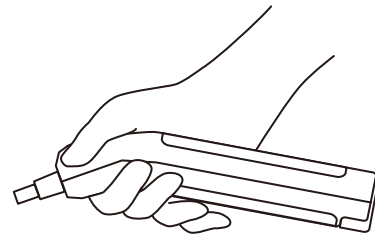

Without all fingers attached to the electrodes

Contact condition

- **If your arms make skin-to-skin contact, the results can only be used as reference data.**

Checking the Contained Items

en

Before Use

Checking the Contained Items (Platform, Control box, Accessories)

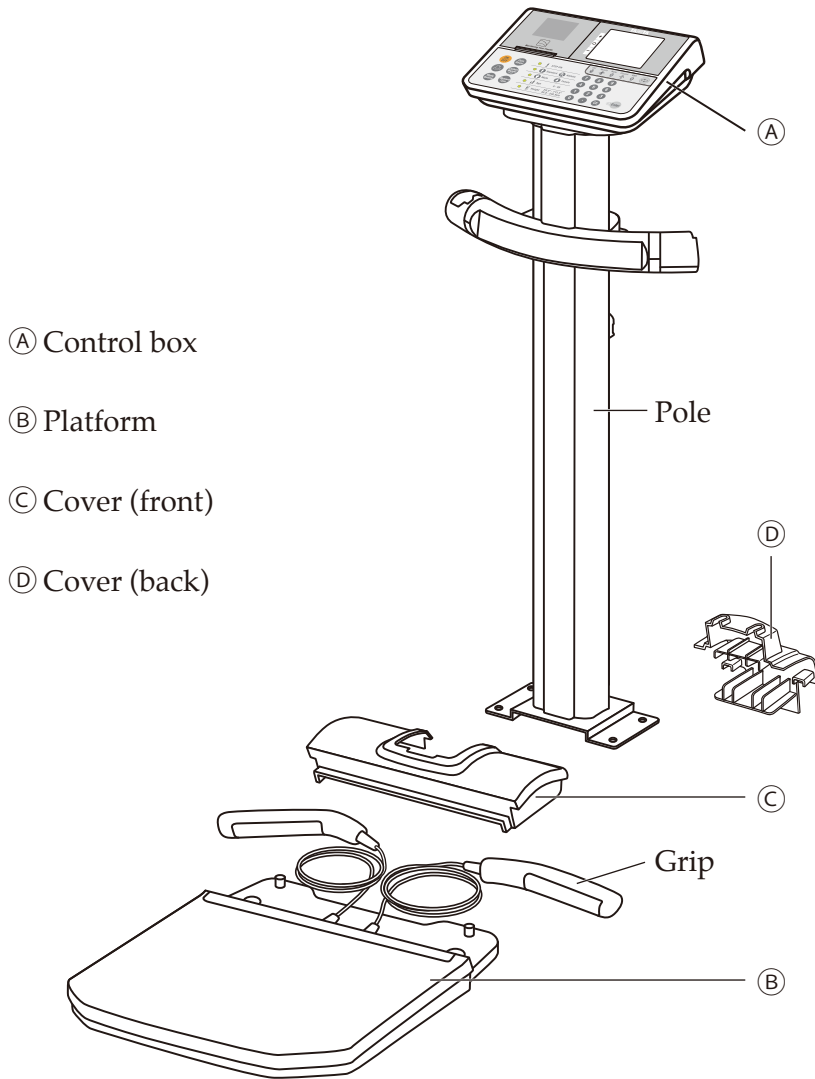

Accessories

AC adaptor



Assembly Guide

AC cord



Measurement Guide

Screws x 4

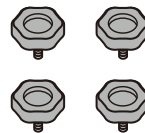

Mats x 3

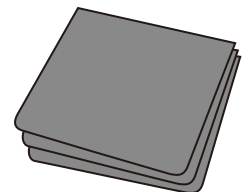

Thermal paper roll x 1

Contact us if you do not have all of the components listed above (See back cover).

Positioning the Scale/Setting up the Mat

en

Before Use

Positioning the Scale

Checking that the equipment is level.

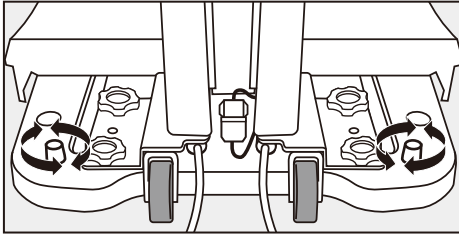

Unfasten the knobs on the platform and stabilize the feet (x 4) and adjustable feet (x 2).

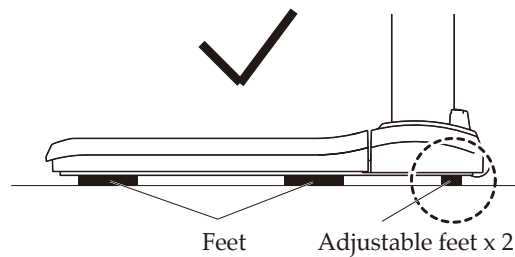
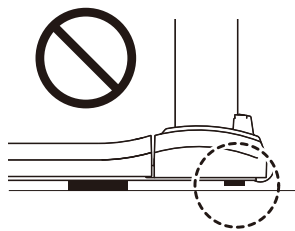
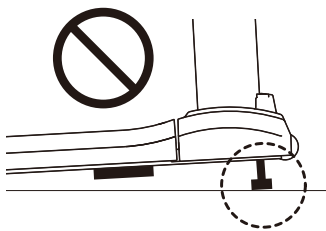

Note

For accurate measurements, make the equipment as even as possible.

Setting up the Mat

You can use the device while wearing your shoes.
Use the mat to make sure that you do not slip on the platform.
The mat also protects the device against stains and damage.

1

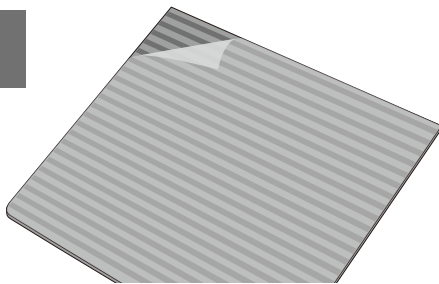

Remove the protective sheet under the mat.

2

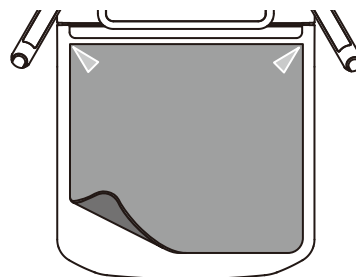

Align the mat with the platform.

Note

If the equipment is being used for measurement every day, the mat should be replaced around once a month. If you are unsure about anything, please contact our customer service division.

Part Names & Connection Procedure

en

Before Use

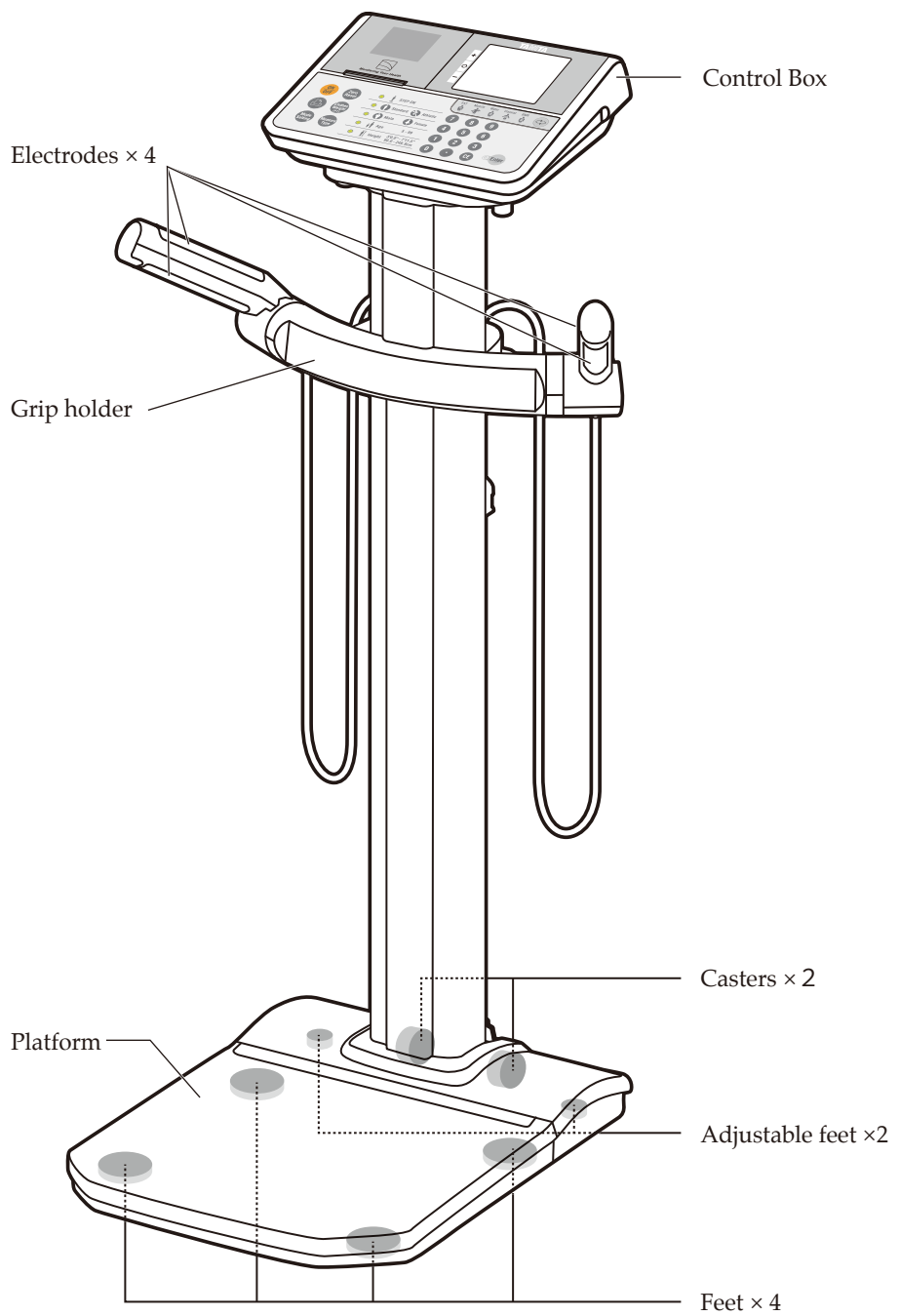

Symbols and their Meanings

	Positive polarity		SD card		WEEE - Waste Electrical and Electronic Equipment Directives
	Alternating current		Serial interface		For indoor use only
	Input, Output		Direct current		See the instructions
	Caution Refer to the attached notes.		Serial number		Manufacturer
	CE marking				

Control Box

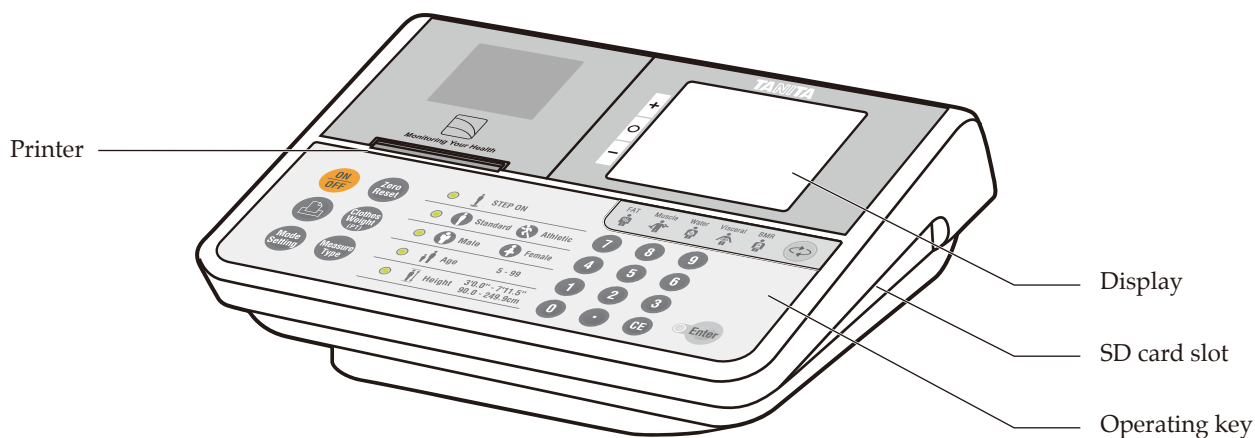

Connecting the Power

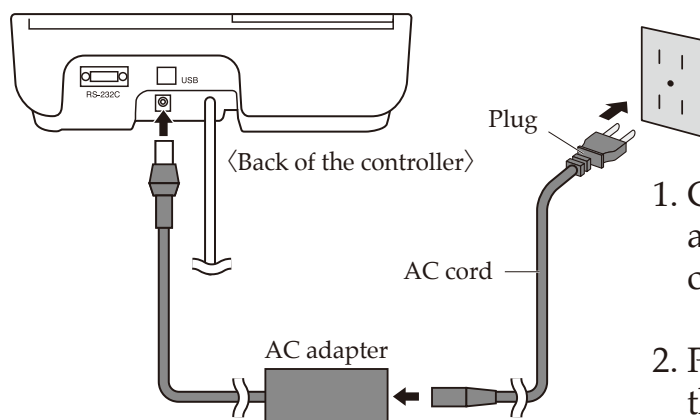

1. Connect the AC adapter to the AC cord and plug the AC adapter into the controller jack.
2. Plug the plug on the AC adapter into the wall socket.

Warning

Do not have wet hands while handling the plug or AC adapter, as this can cause electrical shocks.

Part Names & Connection Procedure (continued)

en
Before Use

Display and Keys



Meanings of the LED Indicators and Keys

	Turn ON/OFF the power		Display Body Fat (percentage and mass) *Not measured value but calculated value
	Feeds the printer paper		Display Body Muscle (percentage and mass) *Not measured value but calculated value
	Set various functions		Display Body Water (percentage and mass) *Not measured value but calculated value
	Reset zero point		Display Visceral Fat Rating
	Set preset value (Clothes weight)		Display Basal Metabolic Rate
	Select measurement mode		Indicate to step on
	Select measurement mode		Select the body type from "Standard mode" or "Athletic mode"
	Select measurement mode		Select the gender from "Male" or "Female"
	Select measurement mode		Enter the age between 5 to 99 years
	Select measurement mode		Enter the height between 3'0.0" to 7'11.5" / 90.0 to 249.9cm
	Select measurement display		Confirms the entered numerical value.

Setting the Thermal Paper Roll

1 (1) Turn the power OFF and push the handle on the left hand side of the controller.

(2) Open the printer cover.

(3) Set the printer paper in place.

Peel off the adhesive and pull out approximately 10cm of paper from the thermal paper roll.

(4) Replace the printer cover to its original place.

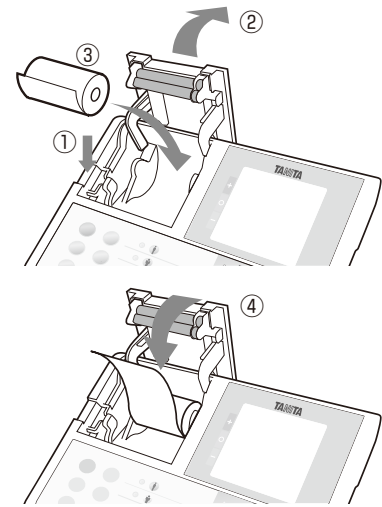

2 Press  to turn on the device.

After all the indicators are displayed,  is displayed.

If the device is turned on with the printer cover open,  is displayed.

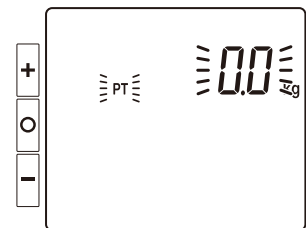

3 Press . The printer paper is cut automatically, and the settings are completed.

Paper is not automatically cut when 'Auto Cut' is set to 'Off'.

Note

Cutting automatically setting → See P.16 Setting item 4

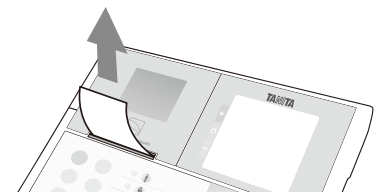

Setting an SD Card

en

Before Use

- 1** When the power is turned OFF, insert an SD card into the slot with the logo side facing upwards.

Make sure the card is facing in the correct direction when inserting it.

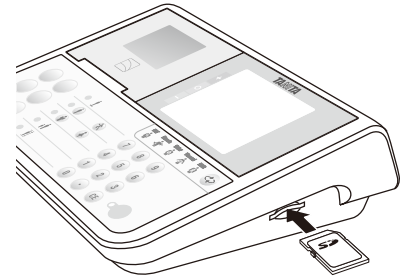

- 2** Press  to turn on the device.

- 3** When the device detects the SD card, the mark on the right appears in the upper left corner of the screen.

Be sure to insert and remove the SD card when the device power is off to avoid damaging the SD card.

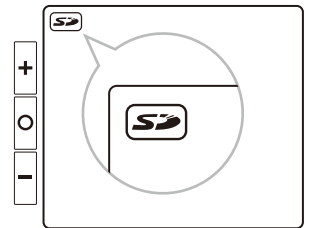

Note

Compatible with SD and SDHC memory cards.
Not compatible with SDXC memory cards.

Power Supply

Turning the Main Power ON/OFF

Turning the main power ON

Press the  key to turn on the power.
The initial screen is displayed.

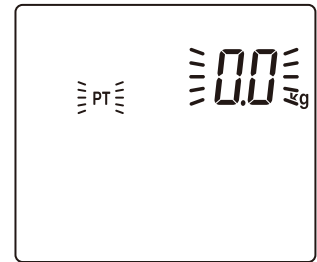

Turning the main power OFF

Press the  key to turn the power OFF.

Emergency Shut Down

Keep the area around the plug socket clear during operation of the equipment in case of an emergency.

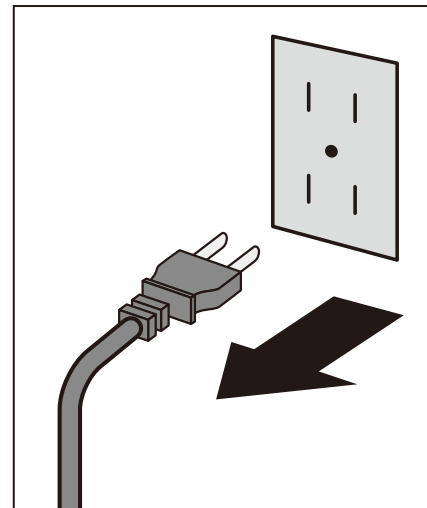

Settings

en

Before Use

1 Press the  key to change the mode.
The setting screen is displayed.

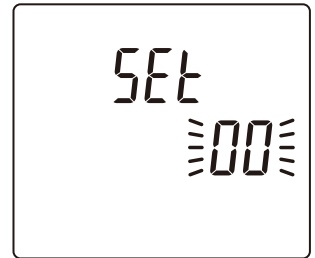

Note

- The  key cannot be used when the scale is measuring weight or results are displayed while standing on the platform after measurement.

2 Select the setting item from the list below.
Enter numerical values and press the  key.

Setting item List  → Save changes and return

 → Correct input number or cancel

No.	Setting item	Default
0	Check the software version	-
1	Date and time → See Note below	2018.1.1 00:00
2	Number to be printed automatically (0-3 sheet(s))	1
4	Cutting automatically (0: off, 1: on)	1
5	Beep sound (0: off, 1: on)	1
7	ID number (Automatic count up) (0: off, 1: on)	0
8	Measurement flow (0: Two step flow / Measure body weight first, 1: One step flow / Enter personal info first) * Measurement flow → See P.18	0
9	Body type selection (Athletic mode) (0: off, 1: on) * Athletic mode → See P.18 & P.23	1

No.	Setting item	Default
10	Height input unit (0: 0.1cm increments, 1: 2cm increments)	0
11	Automatic determination time of input information (0-9 second(s)) * 0: Disables this function	0
16	Unit change (0: kg, 1: lb)	1
18	Target body fat ratio input (0: off, 1: on)	0
19	Printout Language (1: English, 2: French, 3: German, 4: Italian, 5: Spanish, 6: Turkish)	1
20	Printout contents (1: full, 2: short)	1
21	Timeout function of result display (0: disable, 1: enable)	0
23	BMR kJ unit display (0: off, 1: on)	1
45-68	Printing item settings (0: off, 1: on) → See P.24	1
80	Reading Stored Measurement Result Data → See P.27	-

Note

Enter the year, month, day, hour and minute.
The date format is "yyyy mm dd hh:mm"
(Date input range: 2018 01 01 00:00 to 2099 12 31 23:59)

Example 3:45 pm, 10th October, 2018
"2018" "10 10" "15:45"

To enter a number with 1 digit (0 to 9), press "0" first.

Press the  key again to return to the measurement screen.

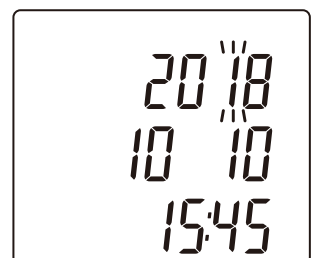

Select the Measurement Mode

Select the measurement mode by pressing the  key.

The measurement mode is switched in the following order when the  key is pressed:

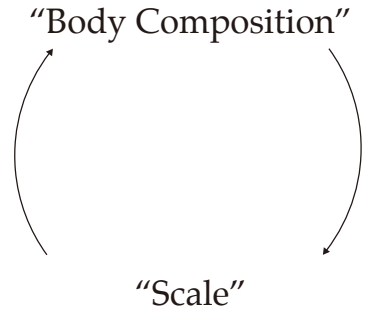

The “” mark is displayed when the scale mode is selected.

Body Composition Mode

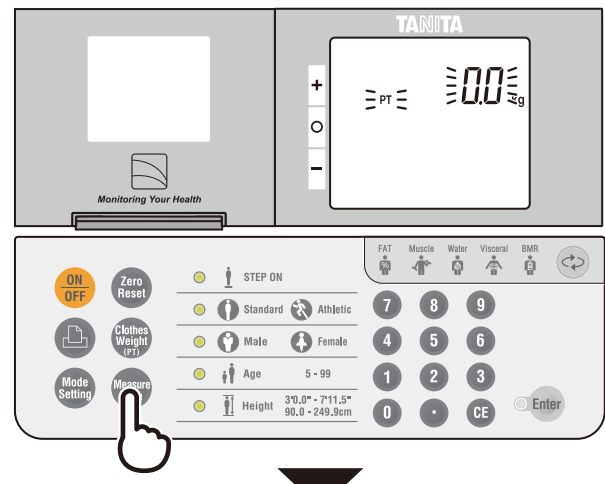

Scale Mode

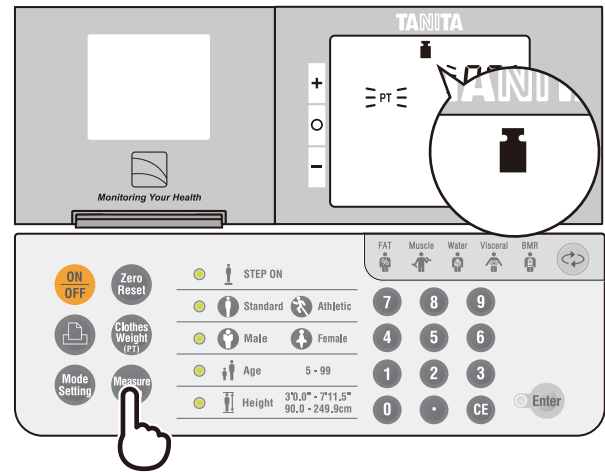

Taking a Measurement

en

Body Composition Mode (Two step flow Measure body weight first)

How to Use

1 Set the clothes weight after 0.0lb (0.0kg) is displayed. (clothes weight)

Set the clothes weight after 0.0lb (0.0kg) is displayed. When undertaking measurements with your shoes on, count the weight of the shoes toward the clothes weight (0.0 to 20.0lb/0.0 to 10.0kg).

Standard clothes weight: summer 1.0kg, winter 2.0kg
Standard shoes weight:



Pumps
0.2kg



Running shoes
0.5kg



Sneakers
0.7kg



Leather shoes
1.0kg



Boots
2.5kg

*The weight is based on the standards as researched by TANITA.

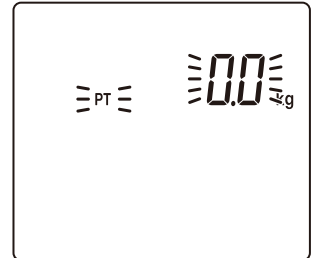

2 Input a user ID (16 digits).

This may not be displayed if the ID number function is set to off. If the ID number is set to ON, ID number will be increased automatically. To change ID number manually, press **CE** and enter the preferred ID number.

The ID number range: 0 to 9999999999999999

Note ID number setting → See P.16 Setting item 7

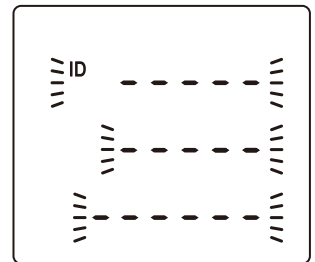

3 Measure body weight.

Step onto the platform, after "STEP on" flashes.

"NET" is displayed when you have entered a tare value (clothes weight).

The "Stabilised" icon (●) appears when the load is stable.

Note

When the One step flow is selected, enter personal information first.

→ See P.16 Setting item 8

If the scale does not detect a load, press **Clothes Weight (PT)** to switch to "Input tare value".

If the scale detects the load, press **Clothes Weight (PT)** to display the entered tare value.

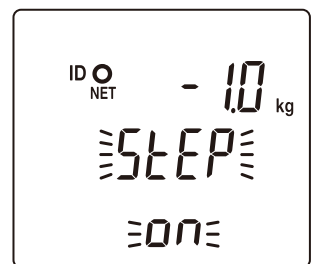

4 Select body type. Standard Athletic

This may not be displayed if the Athletic mode is set to off.

The "A" mark is displayed when the Athletic mode is selected.

Note

Athletic mode setting → See P.16 Setting item 9

Athlete condition → See P.23

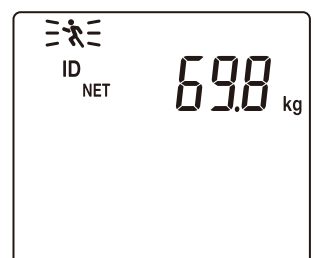

Body Composition Mode

5 Select gender.  Male  Female

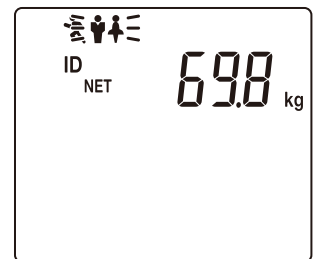

6 Enter age.  Age

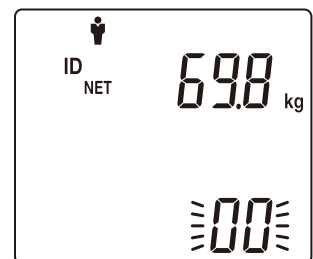
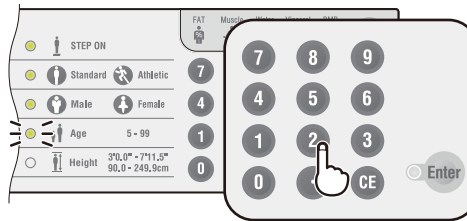

The age range: 5 to 99

7 Enter height.  Height

The height range:
3'0.0" to 7'11.5"
(90.0 to 249.9cm)

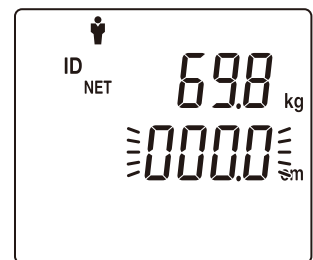
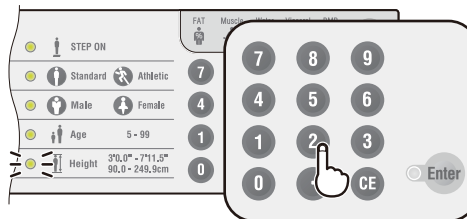

Note Height input unit setting → See P.16 Setting item 10

8 Set target body fat ratio.

This may not be displayed if the target body fat ratio function is set to off.

The body fat ratio range: 4 to 55%

Note Target Body Fat ratio input → See P.16 Setting item 18

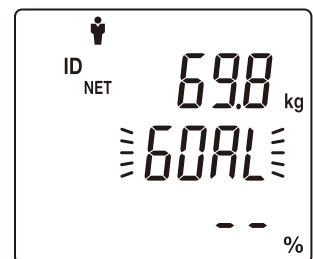

9 Measure body composition.

The scale starts measuring impedance after you have entered all of the personal information. Wait until "9r iP on" is displayed, and remain standing while measuring.

The measurement is complete when all "000000" disappear.

The scale displays the measurement results after measuring the whole body impedance.

The next measuring starts by pressing .

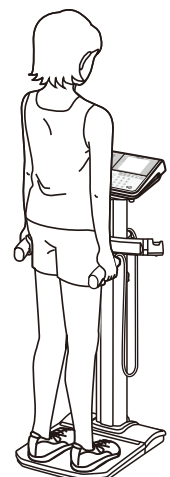
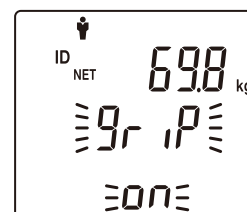

Taking a Measurement (continued)

en

Measurement Results

Output Measurement Results (Body Composition Mode)

The measurement results are displayed on the LCD after measurement is completed.

The results are printed immediately after measurement is completed.

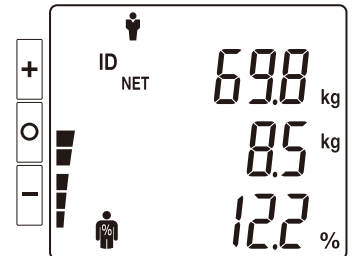

Press the key to select the measurement display.

The measurement display is switched in the following order by pressing the key.

→ "Fat" → "Muscle" → "Body Water" → "Visceral fat rating" → "Basal metabolic rate" → "BMI" →

Body Fat (Applicable age: 5 to 99)

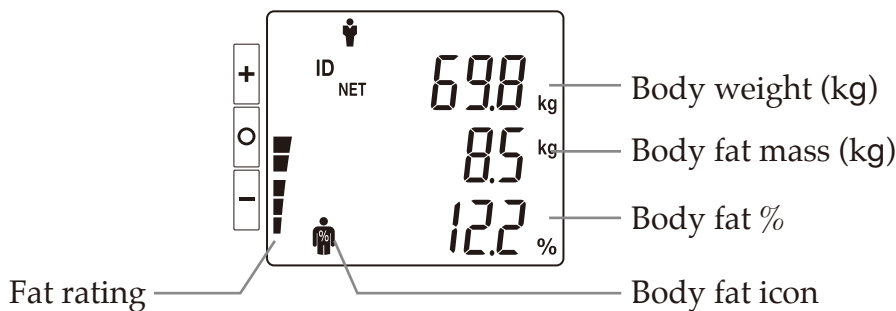

Muscle (Applicable age: 18 to 99)

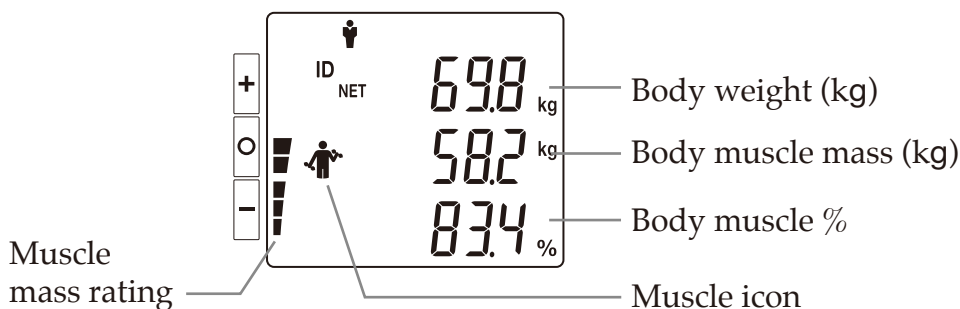

*Muscle mass rating compared to the general population.

Measurement Results

Total Body water (Applicable age: 5 to 99)

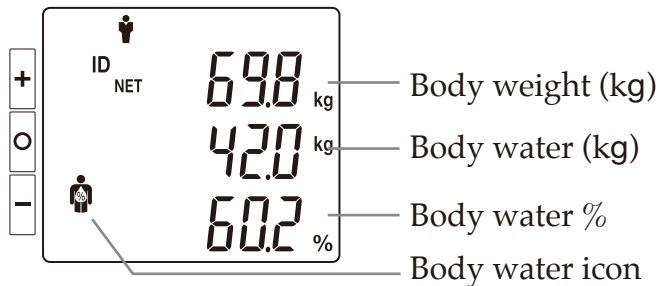

Visceral fat rating (Applicable age: 18 to 99)

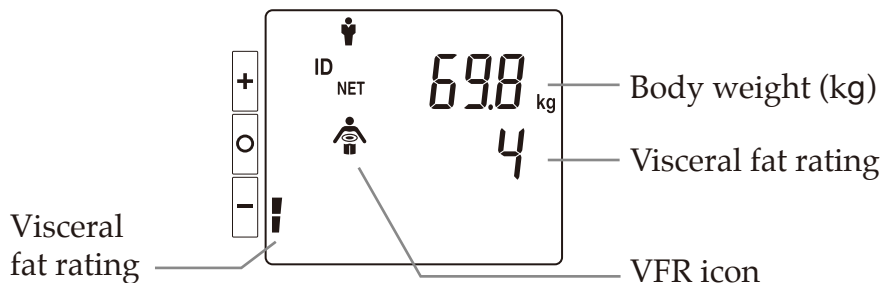

Basal metabolic rate (Applicable age: 5 to 99)

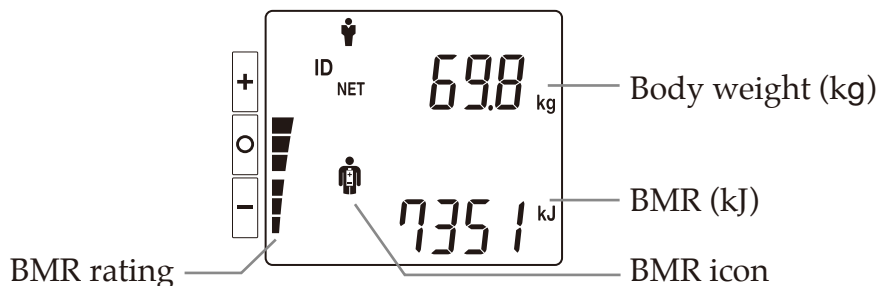

*Basal metabolic rate level compared to the general population.

Note BMR kJ unit display ON/OFF setting → See P.16 Setting item 23

Body Mass Index (BMI) (Applicable age: 5 to 99)

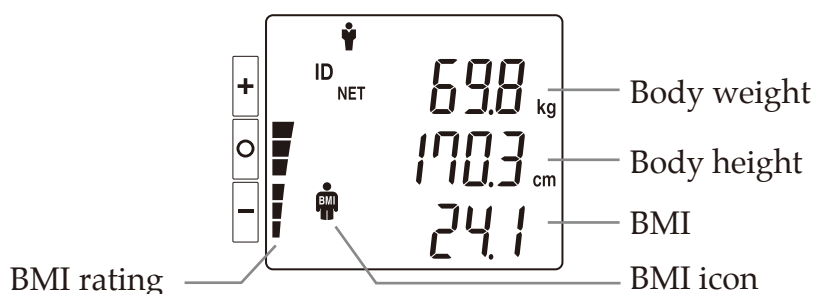

“O” flashes if measuring posture is incorrect.

The results can only be used as reference data. → See P.29

Taking a Measurement (continued)

en

Scale Mode

The “” icon is displayed when the scale mode is selected.

1 Set the clothes weight after 0.0lb (0.0kg) is displayed (clothes weight).

Set the clothes weight after 0.0lb (0.0kg) is displayed. When undertaking measurements with your shoes on, count the weight of the shoes toward the clothes weight (0.0 to 20.0lb / 0.0 to 10.0kg).

Standard clothes weight: summer 1.0kg, winter 2.0kg
Standard shoes weight:



*The weight is based on the standards as researched by TANITA.

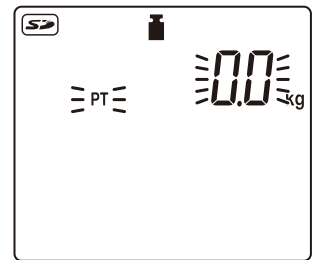

2 Input a user ID (16 digits).

This may not be displayed if the ID number function is set to off.

If the ID number is set to ON, ID number will be increased automatically.

To change ID number manually, press  and enter the preferred ID number.

The ID number range is from 0 to 9999999999999999.

Press  to enter tare value (clothes weight).

The tare value range is 0.0 to 20.0lb / 0.0 to 10.0kg.

Note ID number setting → See P.16 Setting item 7

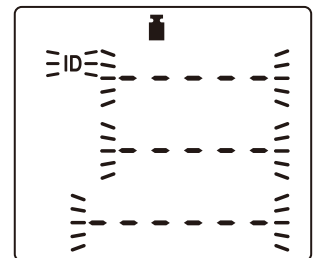

3 Measure body weight.

Step onto the platform, after “STEP on” flashes.

“NET” is displayed when you have entered a tare value (clothes weight).

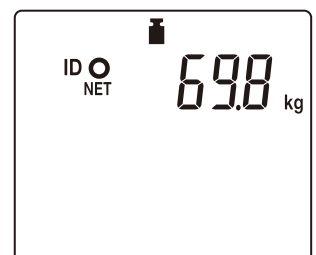

General Instructions for Body Composition Measurement

Athletic Mode

- **Recommended for those who are 18 years or older and meet the following conditions.**
 - People who carry out 12 or more hours of general or cardiovascular exercise a week.
 - People who belong to a sport team or a sport organization with the aim of participation in competition, etc.
 - People who are professional athletes.
 - People who are undertaking training such as bodybuilding to increase their muscle mass.

Target Body Fat

- **A target body fat % should be set by a professional only. TANITA is not responsible for setting the appropriate target body fat % for specific individuals.**

Attention

- **Posture when measuring.**
 - Stand with both feet parallel on the electrodes.
 - Stand without bending knees.
- **The age input range is 5 to 99 years old.**
Input age 99 for those who are 100 years or older.

Note

- Inaccurate results may be reported after excessive food/fluid intake, or after periods of intense exercise.
- If clothes weight is input, clothes weight is subtracted from the weight measurements.

Output and Storage of Measurement Results (continued)

en

How to Use

Select Printing Data

- 1 Press the  key to change the mode.
The setting screen is displayed.

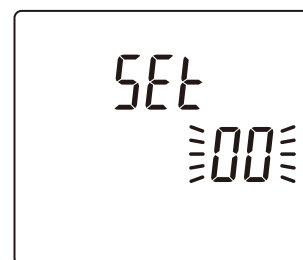

Note

- The  key cannot be used when the scale is measuring weight or results are displayed while standing on the platform after measurement.

- 2 Select the printing item from the list below.

Select the No. of the item that you want to change, select whether printing is on or off, and press .

Printing Data 0: off, 1: on

No.	Items	Default	No.	Items	Default
45	Fat Mass	1.on	57	Degree of Obesity	1.on
46	Fat Free Mass	1.on	59	Total Body Water %	1.on
47	Muscle Mass	1.on	58	Desirable Range	1.on
69	Muscle Mass %	1.on	60	Indicator Fat %	1.on
48	Total Body Water Mass	1.on	61	Indicator BMI	1.on
49	Bone Mass	1.on	62	Indicator Visceral Fat Rating	1.on
50	Basal Metabolic Rate (BMR)	1.on	63	Indicator Muscle Mass	1.on
51	Metabolic Age	1.on	64	Indicator BMR	1.on
52	Visceral Fat Rating	1.on	66	Physique Rating	1.on
54	BMI	1.on	67	Bioelectrical data	1.on
56	Ideal Body Weight	1.on	68	TANITA Logo	1.on

Press the  key again to return to the measurement display.

Lists of Contents of the Print Item Preset

Print item	Body composition analyzer						Scale
	Full			Short			
Body Type	Standard	Athletic	Child	Standard	Athletic	Child	
TANITA LOGO	✓	✓	✓	✓	✓	✓	✓
Category Name	✓	✓	✓	✓	✓	✓	✓
Model Number	✓	✓	✓	✓	✓	✓	✓
Date and Time	✓	✓	✓	✓	✓	✓	✓
ID No.	*1	*1	*1	*1	*1	*1	*1
Body Type	✓	✓		✓	✓		
Gender	✓	✓	✓	✓	✓	✓	
Age	✓	✓	✓	✓	✓	✓	
Height	✓	✓	✓	✓	✓	✓	
Clothes Weight	✓	✓	✓	✓	✓	✓	✓
Weight	✓	✓	✓	✓	✓	✓	✓
Fat %	✓	✓	✓	✓	✓	✓	
Fat Mass	✓	✓	✓				
Fat Free Mass	✓	✓	✓				
Muscle Mass	✓	✓					
Muscle Mass %	✓	✓					
Total Body Water	*3	*3	*3				
Total Body Water %	*3	*3	*3				
Bone Mass	✓	✓					
Basal Metabolic Rate	✓	✓	✓				
Metabolic Age	✓	✓					
Visceral Fat Rating	✓	✓					
BMI	✓	✓	✓	✓	✓	✓	
Ideal Body Weight	✓						
Degree of Obesity	✓						
Desirable Range	✓	✓	✓				
Target Body Fat %	*2	*2	*2	*2	*2	*2	
Indicator Fat %	✓	✓	✓				
Indicator BMI	✓	✓					
Indicator Visceral Fat Rating	✓	✓					
Indicator Muscle Mass	✓	✓					
Indicator BMR	✓	✓					
Physique Rating	✓	✓					
Bioelectrical Data	✓	✓	✓	✓	✓	✓	
Contact condition	✓	✓	✓	✓	✓	✓	

See P.26 for an example of preset print.

*1: These items are not default.

*2: If Target Body Fat % is on, and if the Target Body Fat % has been input, it will print out.

*3: Total Body Water will not print if there is an error.

Output and Storage of Measurement Results (continued)

In the Case to Select the Print Item Preset

All items can be printed in Standard Mode.

*In the Case to Select the Print Item Preset

Weight

- Measured weight.

Fat %

- Fat % is amount of body fat as a proportion of body weight.

Fat mass

- Total weight of fat mass in the body.

FFM

- Fat Free Mass is comprised of muscle, bone, tissue, water, and all other fat free mass in the body.

Muscle mass/Muscle mass %*

- Bone-free lean tissue mass (LTM)

TBW/TBW %

- Total Body Water is the amount of water retained in the body. TBW is said to comprise between 50 to 70% of total body weight. Generally, men tend to have higher water weight than women due to a greater amount of muscle.

Bone mass*

- Bone mineral amount included in the entire bone.

BMR

- Basal Metabolic Rate represents the total energy expended by the body to maintain normal functions at rest such as respiration and circulation.

Metabolic age*

- Metabolic age is evaluated younger when a muscular amount is larger, and BMR is higher.

Visceral fat rating*

- Visceral fat rating feature indicates the rating of visceral fat.

BMI

- Calculated with "weight (kg) / height(m)²"

Ideal body weight*

- Ideal body weight is a value for which the BMI is 22.

Degree of obesity*

- Calculated as (weight – Ideal body weight) / Ideal body weight × 100.

*18 to 99 years only

For those who are 17 years old or younger, only the body fat % is displayed as the standard value.



Please consult your doctor before you start a body weight management program. TANITA is not responsible for the target body fat ratio.

TANITA	
BODY COMPOSITION ANALYZER DC-13CU	
01/APR/2018 10:10	
INPUT	
ID	NO.0000000000000001
BODY TYPE	STANDARD
GENDER	MALE
AGE	37
HEIGHT	170.3cm
CLOTHES WEIGHT	1.0kg
RESULT	
WEIGHT	69.8kg
FAT %	12.2 %
FAT MASS	8.5kg
FFM	61.3kg
MUSCLE MASS	58.2kg
MUSCLE %	83.4 %
TBW	42.0kg
TBW %	60.2 %
BONE MASS	3.1kg
BMR	7351 kJ
METABOLIC AGE	1757kcal
VISCERAL FAT RATING	22
BMI	24.1
IDEAL BODY WEIGHT	63.8kg
DEGREE OF OBESITY	9.4 %
DESTRALABLE RANGE	
FAT %	6.0 - 19.9 %
FAT MASS	5.3 - 15.2kg
TARGET	
TARGET BF% is:	
Predicted weight:	76.6kg
Predicted fat mass:	15.3kg
FAT TO GAIN:	6.8kg
Consult your physician before beginning any weight management program. Tanita is not responsible for determining your targetBF%.	
INDICATOR	
*FAT %	- 0 + ++
*BMI	- 0 + ++
*VISCERAL FAT RATING	13
*MUSCLE MASS	- 0 +
*BMR	- 0 +
*PHYSIQUE RATING	STANDARD
*BIOELECTRICAL DATA	
*R	6.25kHz 50kHz
IR	577.5 497.5
X	-34.1 -51.0

ID

- When it is set with an ID, it is printed out. (The default is without an ID.)

Bioelectrical data

- The table indicates Resistance(R)/Reactance(X) data.

Contact condition mark

- When this mark is printed out it means that your posture during measurement was incorrect. The results can only be used as reference data.

Reading Stored Measurement Result Data

1 Press the  key while the display is on, and select the setting 80.

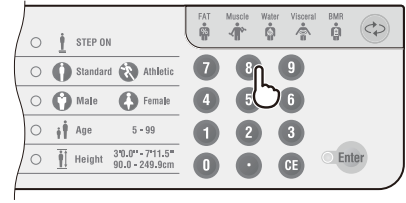

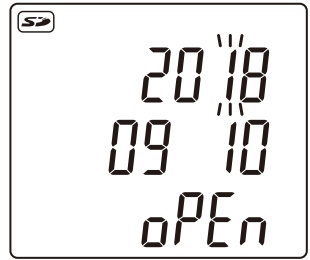

Make sure the SD card is inserted.
Enter the measurement date (YYYYMMDD) using the keypad, then press the Enter key and "oPEn" lights.



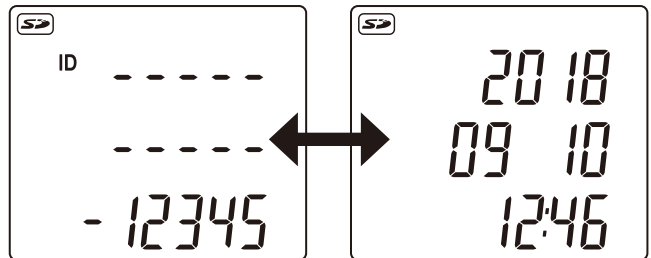

When there is no data matching with the entered date, "F-nonE" is displayed.

2 When a file is present, the ID and measurement data and time of the data saved at the beginning of the file are alternately displayed.

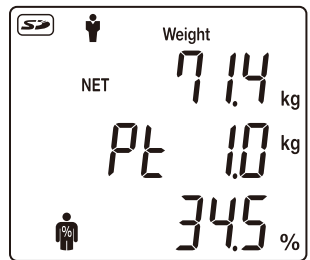

(1) Press the  key, and the ID and measurement date and time of the data saved below are alternately displayed.



(2) Press the  key, and Body weight, Pt (Clothes weight) and Body Fat % are displayed.
*Press the  key to return to one higher level.

Data Output

Outputting measurement results via the USB or RS

The results are output to the PC immediately after measurement is completed.

Data is output in CSV format.

- USB connector (Type B 4 - pin female) and RS-232C are located on the back of the control box.
- Please provide your own cable as necessary as none are included.
USB cable: Type A 4 - pin (male) - Type B 4 - pin (male)
- RS-232C and USB are mutually exclusive.

Data Storage

Data storage of measurement results

The results are saved to the SD card immediately after measurement is completed.

The  icon is displayed when a valid SD card is inserted.

A new file is created on the SD card for each day.

The file is created using the measurement date and time as the file name, as shown below. "YYYYMMDD" (year, month and date)

If "error 12" is shown in the display, this indicates that there is not enough free space left on the SD card.

- Do not remove the SD card when it is storing or reading data.
- Do not turn off the main power when the SD card is storing or reading data.

*Compatible with SD and SDHC memory cards. Not compatible with SDXC memory cards.

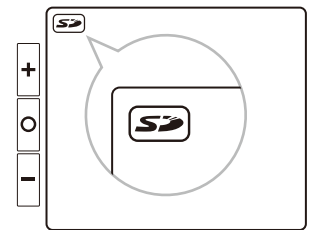

Troubleshooting

Please check the following before requesting repair.

	Problem	Solution
Measurement	Error with impedance measurement "Err40" is displayed.	<ul style="list-style-type: none"> • Hold the grip with bare hands. If the palms are dry, use a dropper to apply about 0.5mL of water before measurement. • Check the input details.
	Error with zeroing "uuuuu" is displayed.	<ul style="list-style-type: none"> • Turn off the power and remove anything on the platform, then turn on the power and try measuring again.
	The weight value does not stabilize.	<ul style="list-style-type: none"> • Is the equipment placed on a vibrating surface? • Is the measuring platform tilted? • Is something blocking the gap in the measuring platform? • Remove any inserted objects.
Display	Nothing is displayed, even when the power is turned on.	<ul style="list-style-type: none"> • Confirm that the power is connected correctly.
	"-----" is displayed.	<ul style="list-style-type: none"> • The measured weight exceeds weighing capacity.
	"○" flashes.	<ul style="list-style-type: none"> • "○" flashes if measuring posture is incorrect. The results can only be used as reference data. → See P.7
Printer	Run out of print paper "P-End" is displayed.	<ul style="list-style-type: none"> • Supply paper. • In the case that the printer is not used, press  key and redo the initial setting.
	Printer cover open "COPEn" is displayed.	<ul style="list-style-type: none"> • Properly close it. • Check that the printer paper is not slanted.
SD card	"Sd-F" is displayed.	<ul style="list-style-type: none"> • Insufficient space on the SD card. ⇒ Transfer or delete data from the SD card.
	"Sd-P" is displayed. or "Sd-E" is displayed.	<ul style="list-style-type: none"> • An SD memory card drive error might have occurred. ⇒ Turn off the power off and on. ⇒ Format the SD memory card. ⇒ The device might be damaged.

Specifications

en

If Necessary

Model Number		DC-13CU
Power Source		AC adapter Input: 100 – 240V ~ Output: 12V ---
Electric Current Range		25VA
Impedance Measurement	Measurement System	Dual-frequency 4 electrode
	Measurement Frequency	6.25kHz/50kHz
	Electrode Materials	Plastic plated
	Measurement Part	Between both hands
	Measurement Range	150.0 to 1,500.0Ω (0.1Ω increments)
	Accuracy at First Calibration	±2%
Weight Measurement	Measurement System	Strain gauge load cell
	Range	600lb (270kg) (including preset tare value)
	Minimum Graduation	0.2lb (0.1kg)
	Accuracy at First Calibration	±0.4lb (±0.2kg)
Display		LCD screen
Interface		USB B-type connector (device)
		RS-232C
		SD card
Usage Conditions Range	Temperature	5 to 35°C
	Relative Humidity	30 to 80% (without condensation)
Storage Conditions Range	Temperature	-10 to 60°C
	Relative Humidity	10 to 90% (without condensation)
Product Weight		12kg
Product Size		D23.7×W22.4×H40.4in/D603×W568×H1027mm

*Compatible with SD and SDHC memory cards. Not compatible with SDXC memory cards.

Input Items	Clothes Weight	0.0 to 20.0lb (0.2lb increments) 0.0 to 10.0kg (0.1kg increments)
	ID No.	16 digits
	Gender	Female/Male
	Body Type	Standard/Athletic * ¹
	Age	5 to 99 years
	Height	3'0.0" to 7'11.5" (0.5 inch increments) 90.0 to 249.9cm (0.1cm increments)
	Target Body Fat %	4 to 55% (1% increments)
Output Items	ID No.	16 digits
	Gender	Female/Male
	Body Type	Standard/Athletic * ¹
	Age	5 to 99 years
	Height	3'0.0" to 7'11.5" (0.5 inch increments) 90.0 to 249.9cm (0.1cm increments)
	Clothes Weight	0.0 to 20.0lb (0.2lb increments) 0.0 to 10.0kg (0.1kg increments)
	Weight	4.0 to 600lb (0.2lb increments) 2.0 to 270.0kg (0.1kg increments)
	Fat %	3.0 to 75.0% (0.1% increments)
	Fat Mass	0.2lb/0.1kg increments
	FFM	0.2lb/0.1kg increments
	Muscle Mass *²	0.2lb/0.1kg increments
	Muscle Mass % *²	0.1% increments
	Muscle Mass Score *²	1 to 24 (1 increments)
	BMI	0.1 increments
	Bone Mass *²	0.2lb/0.1kg increments
	Basal Metabolic Rate	1kcal/1kJ increments
	Basal Metabolic Rate Score *²	1 to 24 (1 increments)
	Metabolic Age *²	1 year increments
	Visceral Fat Rating *²	1 to 59 (1 increments)
	TBW	0.2lb/0.1kg increments
	TBW %	0.1% increments
Ideal Body Weight *² *³	0.2lb/0.1kg increments	
Degree of Obesity *² *³	0.1% increments	
Target Body Fat %		
Bioelectrical Data	Resistance/Reactance	
Contact condition		

*1: Athletic mode can be selected only 18 to 99 years old

*2: 18 to 99 years old

*3: Athletic mode will not be output.

USA and Canada

Federal Communications Commission and Canadian ICES Notice

This equipment has been tested and found to comply with the limits for a Class B digital device, pursuant to Part 15 of the FCC Rules and Canadian ICES-003. These limits are designed to provide reasonable protection against harmful interference in a residential installation. This equipment generates, uses and can radiate radio frequency energy and, if not installed and used in accordance with the instructions, may cause harmful interference to radio communications. However, there is no guarantee that interference will not occur in a particular installation. If this equipment does cause harmful interference to radio or television reception, which can be determined by turning the equipment off and on, the user is encouraged to try to correct the interference by one or more of the following measures:

- Reorient or relocate the receiving antenna.
- Increase the separation between the equipment and receiver.
- Connect the equipment into an outlet on a circuit different from that to which the receiver is connected.
- Consult the dealer or an experienced radio or television technician for help.

Modifications

The FCC requires the user to be notified that any changes or modifications made to this device that are not expressly approved by Tanita Corporation may void the user's authority to operate the equipment.

Disposal



This equipment is electronic device. Please dispose of this equipment appropriately as not general household waste but electronic equipment. Please follow a regional regulation when you dispose of this.

<U.S.A. representative>

TANITA Corporation of America, Inc.

2625 South Clearbrook Drive, Arlington Heights, Illinois 60005, U.S.A. TEL: 1-847-640-9241 FAX: 1-847-640-9261 <http://www.tanita.com>

<Manufacturer>

TANITA Corporation

1-14-2, Maeno-cho, Itabashi-ku, Tokyo 174-8630, Japan TEL: +81 (0) 3-3968-7048 FAX: +81 (0) 3-3967-2661 <http://www.tanita.co.jp>

TANITA Europe B.V.

Hoogoorddreef 56-E,
1101 BE Amsterdam, the Netherlands
TEL: +31-20-560-2970
FAX: +31-20-560-2988
<http://www.tanita.eu>

TANITA Health Equipment H.K.LTD.

Unit 301-303, Wing On Plaza, 3/F., 62 Mody Road,
Tsimshatsui East, Kowloon, Hong Kong
TEL: +852-2834-3917
FAX: +852-2838-8667
www.tanita.asia

TANITA India Private Limited

A-502, Mittal Commercial, Off. M.V. Road (Andheri Kurla Road),
Marol, Andheri-East, Mumbai 400059, Maharashtra, India
TEL: +91-81-697-28173
www.tanita.co.in

TANITA (Shanghai) Trading Co., Ltd.

Room 8005, 877 Huai Hai Zhong Lu, Shanghai,
The People's Republic of China
TEL: +86-21-6474-6803
FAX: +86-21-6474-7901
www.tanita.com.cn